

# AUTOMOTIVE RELAYS

## Twin relays/Single relays

### DESCRIPTION

The NEC/TOKIN power relays can meet the requirements of high quality and reliability in automotive electronics applications.

The EN2, EP2, ET2 and EX2 series are the twin relays which have two units in one package and smaller than conventional two relays. The EN2 and EP2 series are divided into two types for different usage. One is H bridge type and the other is separate type. The ET2 series is only H bridge type. The EX2 series is only separate type.

The EN2 series is suitable for heavy load applications (35A max.). The EP2, ET2 and EX2 series are designed for medium load applications (25A max.). The EP1, ET1 and EX1 series are the 1c contact form relays. The EQ1 series have the 1c contact form relay and the 1a contact form relay.

Many of these relays have been used in automotive electronics applications throughout the world.

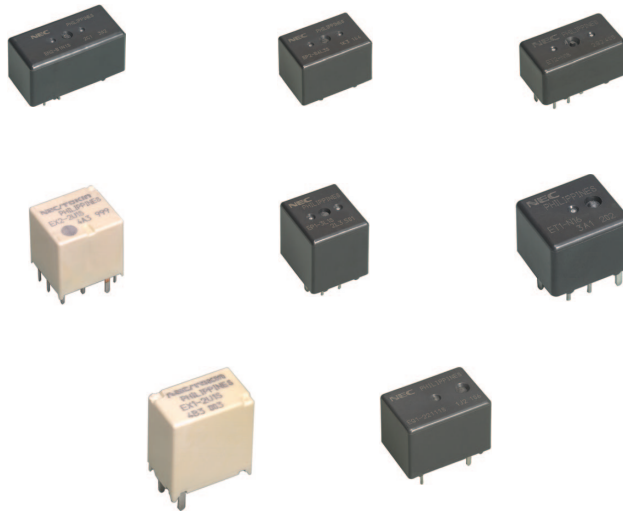

© NEC/TOKIN Corporation 2006



- All specifications in this catalog and production status of products are subject to change without notice. Prior to the purchase, please contact NEC Tokin for updated product data.
- Please request for a specification sheet for detailed product data prior to the purchase.
- Before using the product in this catalog, please read "Precautions" and other safety precautions listed in the printed version catalog.

EN2 SERIES

FEATURES

- Twin relay for motor and solenoid reversible control
- 30% less relay space than conventional two relays
- Contact switching current of 35 A max.
- High performance and productivity by unique symmetrical structure
- Flux tight housing
- Delivered in stick-tube for automatic insertion machine
- Washable type available



PART NUMBERS AND COIL RATINGS

At 20°C (68°F)

Part Number		Nominal Voltage (Vdc)	Coil Resistance ( $\Omega \pm 10\%$ )	Nominal Current (mA)	Must Operate Voltage (Vdc)	Must Release Voltage (Vdc)	Nominal Operate Power (W)
H bridge Type	Separate Type						
EN2-1N1S	EN2-1N1ST	12	125	96.0	6.5	0.6	1.15
EN2-1N2S	EN2-1N2ST	12	125	96.0	7.0	0.6	1.15
EN2-2N3S	EN2-2N3ST	12	180	67.0	7.5	0.6	0.8
EN2-2N4S	EN2-2N4ST	12	180	67.0	8.0	0.6	0.8
EN2-3N4S	EN2-3N4ST	12	225	53.0	8.0	0.9	0.64
EN2-3N5S	EN2-3N5ST	12	225	53.0	8.5	0.9	0.64

PART NUMBER SYSTEM

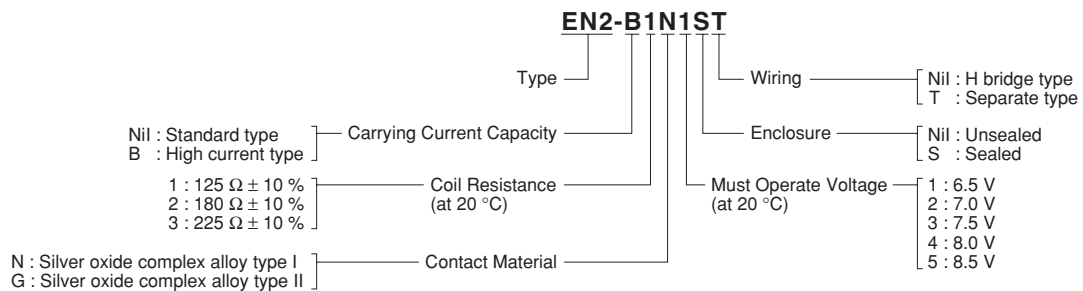
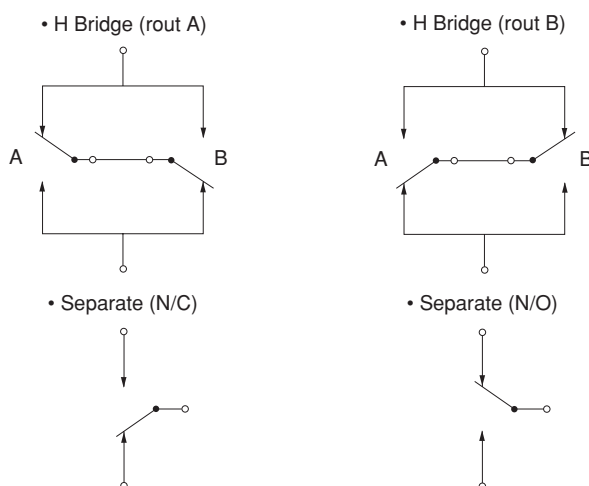
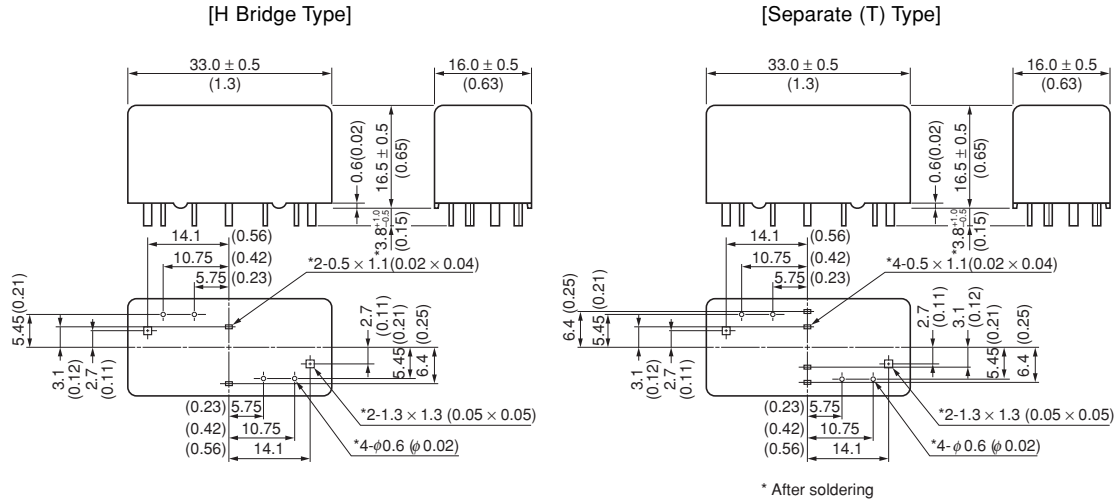

Figure 1 Contact Resistance\*



● All specifications in this catalog and production status of products are subject to change without notice. Prior to the purchase, please contact NEC Tokin for updated product data.  
 ● Please request for a specification sheet for detailed product data prior to the purchase.  
 ● Before using the product in this catalog, please read "Precautions" and other safety precautions listed in the printed version catalog.

DIMENSIONS mm (inch)



PCB PAD LAYOUT and SCHEMATICS (bottom view) mm (inch)

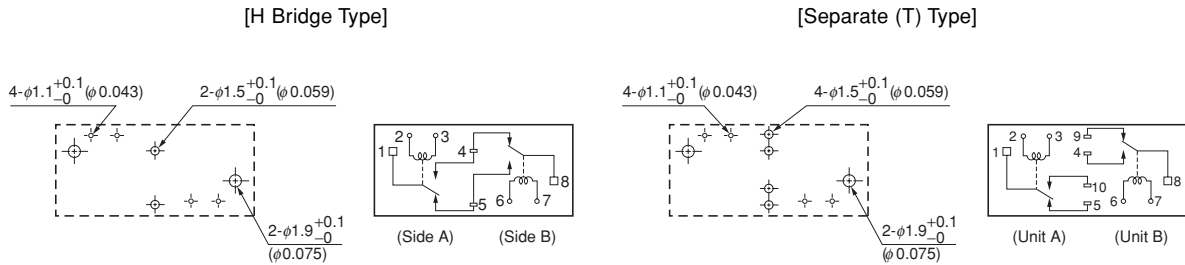

SPECIFICATIONS

At 20°C (68°F)

Items	Specification	
	EN2-(Standard)	EN2-B (High Current)
Contact Form	1 Form c × 2 (H Bridge Type or Separate Type)	
Contact Material	Silver oxide complex alloy (Special types available)	
Contact Resistance (*figure 1)  (measured by voltage drop at 6 Vdc, 7A)	H Bridge (rout A): 8.1 mΩ typ. H Bridge (rout B): 7.8 mΩ typ. Separate (N/C): 3.9 mΩ typ. Separate (N/O): 3.9 mΩ typ.	H Bridge (rout A): 4.9 mΩ typ. H Bridge (rout B): 4.6 mΩ typ. Separate (N/C): 2.3 mΩ typ. Separate (N/O): 2.3 mΩ typ.
Contact Switching Voltage	16 Vdc max. 5 Vdc min.	
Contact Switching Current	35A max. (at 16 Vdc) 1 A min.	
Contact Carrying Current (2 minutes max.)	H Bridge 25A (12Vdc, 20°C) 20A (12Vdc, 85°C) Separate 30A (12Vdc, 20°C) 25A (12Vdc, 85°C)	35A (12Vdc, 20°C) 30A (12Vdc, 85°C) 40A (12Vdc, 20°C) 35A (12Vdc, 85°C)
Operate Time	Approx. 5 ms (at 12 Vdc)	
Release Time	Approx. 7 ms (at 12 Vdc), with diode	
Nominal Operate Power	0.64 W/0.8 W/1.15 W (at 12 Vdc)	
Insulation Resistance	100 MΩ min. at 500 Vdc, Initial	
Breakdown Voltage	500 Vac min. for 1 minute, Initial	
Shock Resistance	98 m/s <sup>2</sup> min. (misoperating)	
Vibration Resistance	10 to 300 Hz, 43 m/s <sup>2</sup> min. (misoperating)	
Ambient Temperature	-40°C to +85°C (-40°F to +185°F)	
Coil Temperature Rise	50°C/W (Contact Carrying Current 0 A)	
Life Expectancy	Mechanical	1 × 10 <sup>6</sup> operations
	Electrical	1 × 10 <sup>5</sup> operations (at 14 Vdc, Motor Load 30 A/7 A)
Weight	Approx. 18 g	



- All specifications in this catalog and production status of products are subject to change without notice. Prior to the purchase, please contact NEC Tokin for updated product data.
- Please request for a specification sheet for detailed product data prior to the purchase.
- Before using the product in this catalog, please read "Precautions" and other safety precautions listed in the printed version catalog.

EP2 SERIES

FEATURES

- Twin relay for motor and solenoid reversible control
- 50% less relay space than conventional two relays
- Contact switching current of 30 A max.
- High performance and productivity by unique symmetrical structure
- Flux tight housing
- Delivered in stick-tube for automatic insertion machine
- Washable type available



PART NUMBERS AND COIL RATINGS

At 20°C (68°F)

Part Number		Nominal Voltage (Vdc)	Coil Resistance ( $\Omega \pm 10\%$ )	Nominal Current (mA)	Must Operate Voltage (Vdc)	Must Release Voltage (Vdc)	Nominal Operate Power (W)
H bridge Type	Separate Type						
EP2-3N1S	EP2-3N1ST	12	225	53.3	6.5	0.9	0.64
EP2-3N2S	EP2-3N2ST	12	225	53.3	7.0	0.9	0.64
EP2-3N3S	EP2-3N3ST	12	225	53.3	7.5	0.9	0.64
EP2-4N3S	EP2-4N3ST	12	300	40.0	7.5	0.9	0.48
EP2-4N4S	EP2-4N4ST	12	300	40.0	8.0	0.9	0.48
EP2-4N5S	EP2-4N5ST	12	300	40.0	8.5	0.9	0.48

PART NUMBER SYSTEM

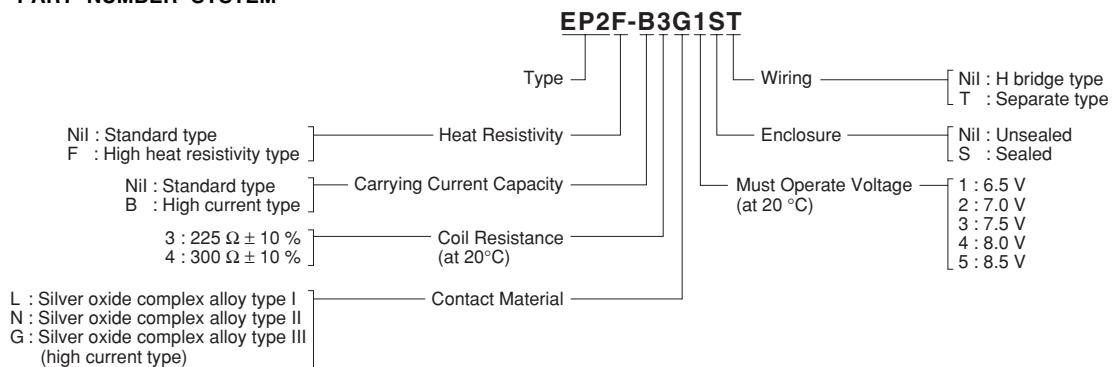
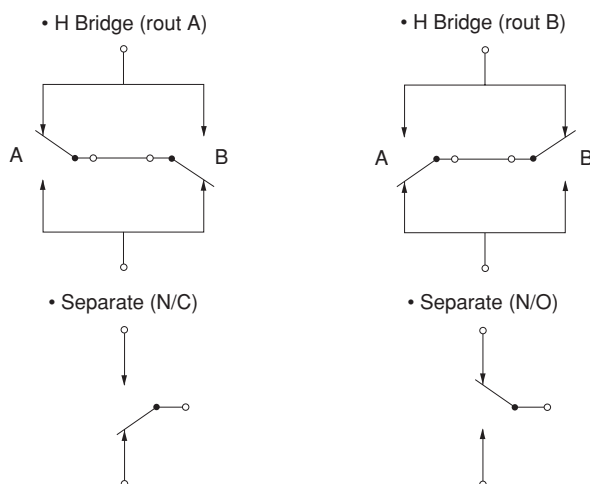
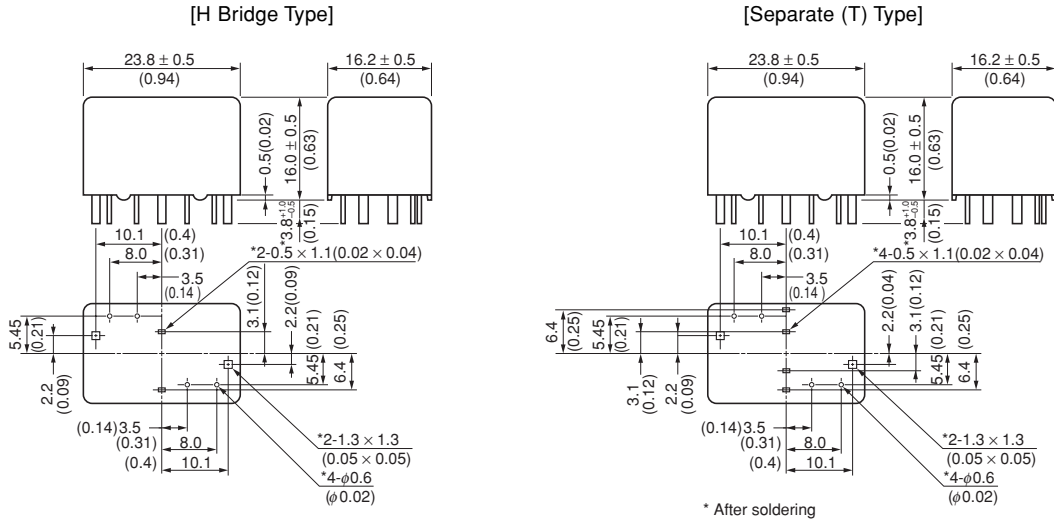

Figure 1 Contact Resistance\*



● All specifications in this catalog and production status of products are subject to change without notice. Prior to the purchase, please contact NEC Tokin for updated product data.  
 ● Please request for a specification sheet for detailed product data prior to the purchase.  
 ● Before using the product in this catalog, please read "Precautions" and other safety precautions listed in the printed version catalog.

DIMENSIONS mm (inch)



PCB PAD LAYOUT and SCHEMATICS (bottom view) mm (inch)

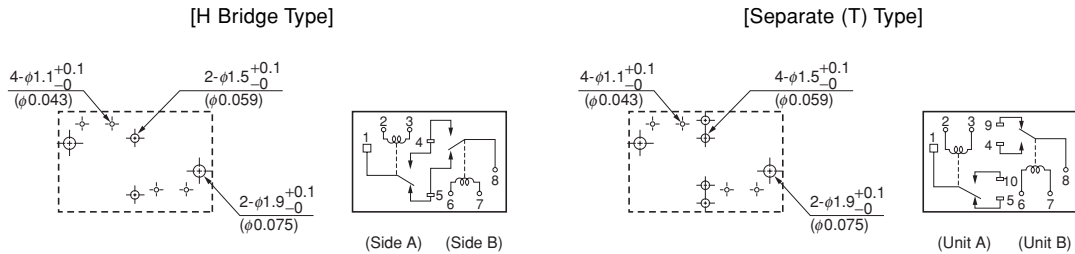

SPECIFICATIONS

At 20°C (68°F)

Items	Specification	
	EP2- (Standard)	EP2-B (High Current)
Contact Form	1 Form c × 2 (H Bridge Type or Separate Type)	
Contact Material	Silver oxide complex alloy (Special types available)	
Contact Resistance (* figure 1)	H Bridge (rout A): 10.7 mΩ typ. H Bridge (rout B): 10.4 mΩ typ. Separate (N/C): 5.2 mΩ typ. Separate (N/O): 5.2 mΩ typ.	H Bridge (rout A): 6.7 mΩ typ. H Bridge (rout B): 6.4 mΩ typ. Separate (N/C): 3.2 mΩ typ. Separate (N/O): 3.2 mΩ typ.
Contact Switching Voltage	16 Vdc max. 5 Vdc min.	
Contact Switching Current	30A max. (at 16 Vdc) 1A min.	
Contact Carrying Current (2 minutes max.)	25A (12 Vdc, 20°C) 20A (12 Vdc, 85°C)	30A (12Vdc, 20°C) 25A (12Vdc, 85°C)
Operate Time	Approx. 5 ms (at 12 Vdc)	
Release Time	Approx. 7 ms (at 12 Vdc), with diode	
Nominal Operate Power	0.48 W/0.64 W (at 12 Vdc)	
Insulation Resistance	100 MΩ min. at 500 Vdc, Initial	
Breakdown Voltage	500 Vac min. for 1 minute, Initial	
Shock Resistance	98 m/s <sup>2</sup> min. (misoperating)	
Vibration Resistance	10 to 300 Hz, 43 m/s <sup>2</sup> min. (misoperating)	
Ambient Temperature	-40°C to +85°C (-40°F to +185°F)	
Coil Temperature Rise	50°C/W (Contact Carrying Current 0 A)	
Life Expectancy	Mechanical	1 × 10 <sup>6</sup> operations
	Electrical	1 × 10 <sup>5</sup> operations (at 14 Vdc, Motor Load 25 A/5 A)
Weight	Approx. 15 g	



- All specifications in this catalog and production status of products are subject to change without notice. Prior to the purchase, please contact NEC Tokin for updated product data.
- Please request for a specification sheet for detailed product data prior to the purchase.
- Before using the product in this catalog, please read "Precautions" and other safety precautions listed in the printed version catalog.

**ET2 SERIES**

**FEATURES**

- Twin relay for motor and solenoid reversible control
- 50% less relay volume than conventional relay (EP2 Series)
- 75% less relay space than conventional relay (EP2 Series)
- 70% less relay height than conventional relay (EP2 Series)
- 50% less relay weight than conventional relay (EP2 Series)
- Contact switching current of 25A max.
- High performance and productivity by unique symmetrical structure
- Flux tight housing
- Delivered in stick-tube for automatic insertion machine
- Washable type available



**PART NUMBERS AND COIL RATINGS**

At 20°C (68°F)

Part Number	Nominal Voltage (Vdc)	Coil Resistance ( $\Omega \pm 10\%$ )	Nominal Current (mA)	Must Operate Voltage (Vdc)	Must Release Voltage (Vdc)	Nominal Operate Power (W)
ET2-B3M1S	12	225	53.3	6.5	0.9	0.64

**PART NUMBER SYSTEM**

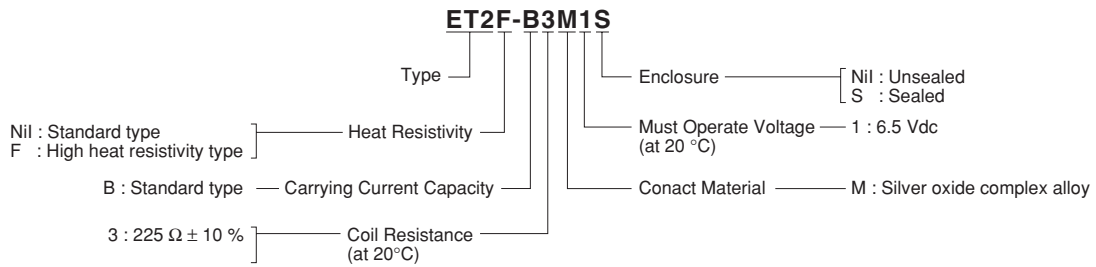

● All specifications in this catalog and production status of products are subject to change without notice. Prior to the purchase, please contact NEC Tokin for updated product data.  
 ● Please request for a specification sheet for detailed product data prior to the purchase.  
 ● Before using the product in this catalog, please read "Precautions" and other safety precautions listed in the printed version catalog.

DIMENSIONS mm (inch)

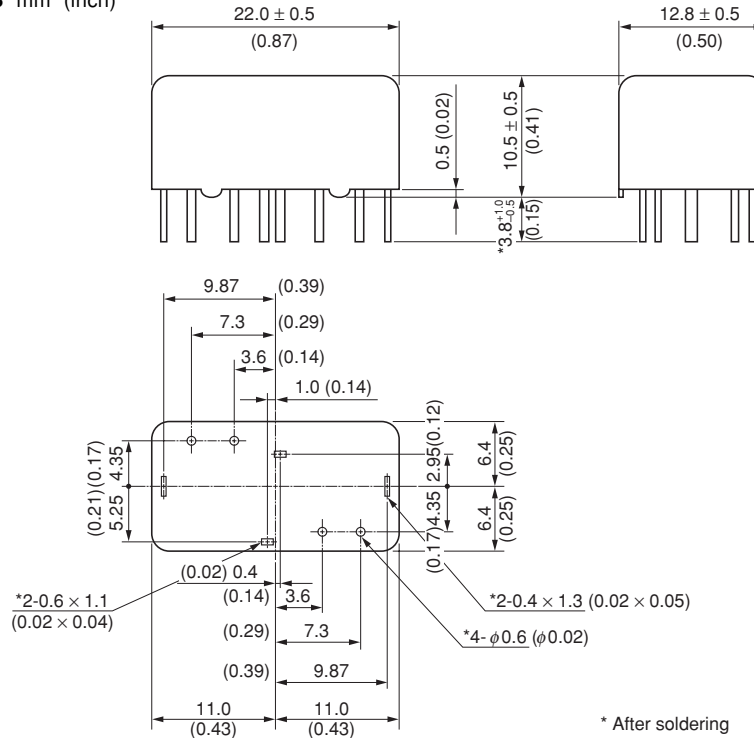

PCB PAD LAYOUT and SCHEMATICS (bottom view) mm (inch)

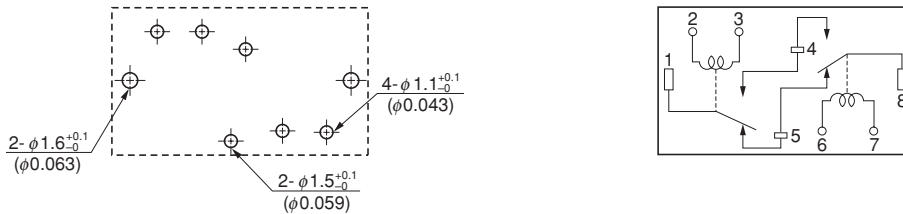

SPECIFICATIONS

At 20°C (68°F)

Items	Specification	
	ET2	ET2F
Contact Form	1 form c × 2 [H Bridge Type]	
Contact Material	Silver oxide complex alloy	
Contact Resistance	4 mΩ typical (measured at 7 A) initial	
Contact Switching Voltage	16 Vdc max. 5 Vdc min.	
Contact Switching Current	25 A max. (at 16 Vdc)	
Contact Carrying Current	30 A (2 minutes max. 12 Vdc at 20°C) 25 A (2 minutes max. 12 Vdc at 85°C)	35 A (2 minutes max. 12 Vdc at 20°C) 30 A (2 minutes max. 12 Vdc at 85°C) 25 A (2 minutes max. 12 Vdc at 125°C)
Operate Time	2.5 ms typical (at nominal voltage) initial	
Release Time	3.0 ms typical (at nominal voltage. with diode) initial	
Nominal Operate Power	640 mW	
Insulation Resistance	100 MΩ min. at 500 Vdc	
Breakdown Voltage	500 Vac min. for 1 minute	
Shock Resistance	98 m/s <sup>2</sup> min. [misoperating]	
Vibration Resistance	10 to 300 Hz, 43 m/s <sup>2</sup> min. [misoperating]	
Ambient Temperature	-40°C to +85°C (-40°F to +185°F)	-40°C to +125°C (-40°F to +257°F)
Coil Temperature Rise	70°C/W (contact carrying current 0 A)	
Life Expectancy	Mechanical	1 × 10 <sup>6</sup> operations
	Electrical	1 × 10 <sup>5</sup> operations (at 14 Vdc, Motor Load 20 A/3 A)
Weight	Approx. 7.5 g	



- All specifications in this catalog and production status of products are subject to change without notice. Prior to the purchase, please contact NEC Tokin for updated product data.
- Please request for a specification sheet for detailed product data prior to the purchase.
- Before using the product in this catalog, please read "Precautions" and other safety precautions listed in the printed version catalog.

**EX2 SERIES**

**FEATURES**

- Twin relay for motor and solenoid reversible control
- 75% less relay volume than conventional relay (ET2 Series)
- 60% less relay space than conventional relay (ET2 Series)
- 88% less relay weight than conventional relay (ET2 Series)
- Contact switching current of 30A max.
- High performance and productivity by unique symmetrical structure
- Flux tight housing
- Delivered in stick-tube for automatic insertion machine
- Washable type available
- Reflowable type available



**PART NUMBERS AND COIL RATINGS**

At 20°C (68°F)

Part Number	Nominal Voltage (Vdc)	Coil Resistance ( $\Omega \pm 10\%$ )	Nominal Current (mA)	Must Operate Voltage (Vdc)	Must Release Voltage (Vdc)	Nominal Operate Power (W)
EX2-2U1S	12	160	75	6.5	0.9	0.9

**PART NUMBER SYSTEM**

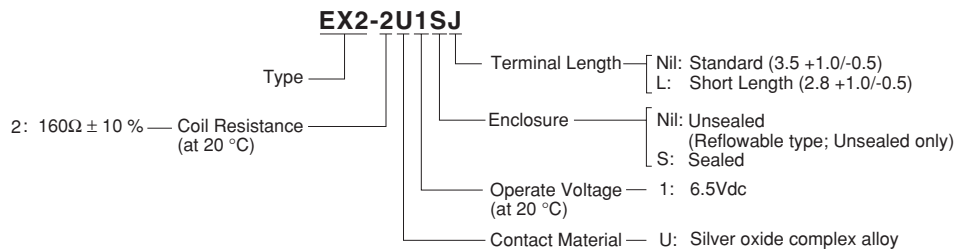

● All specifications in this catalog and production status of products are subject to change without notice. Prior to the purchase, please contact NEC Tokin for updated product data.  
 ● Please request for a specification sheet for detailed product data prior to the purchase.  
 ● Before using the product in this catalog, please read "Precautions" and other safety precautions listed in the printed version catalog.

DIMENSIONS mm (inch)

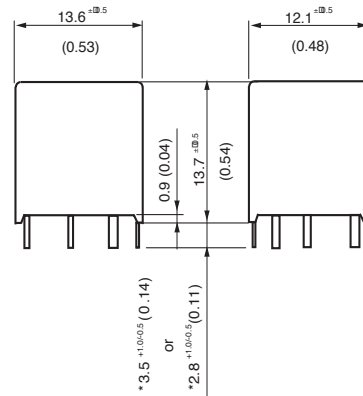

\* After soldering

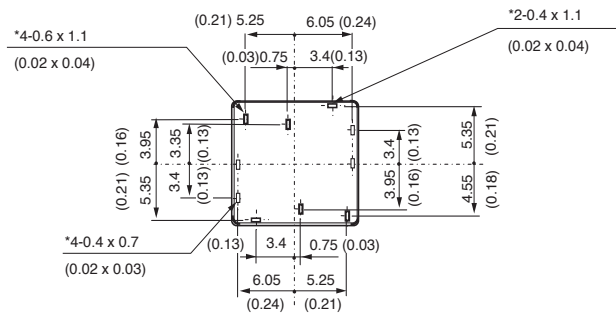

PCB PAD LAYOUT and SCHEMATICS (bottom view) mm (inch)

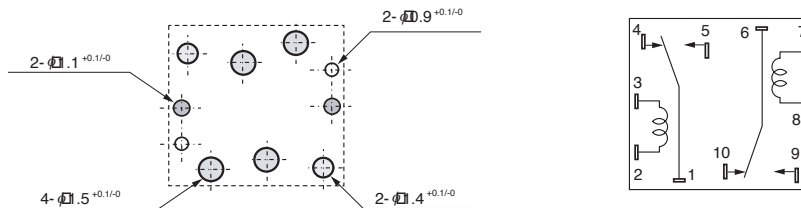

SPECIFICATIONS

At 20°C (68°F)

Items	Specification	
Contact Form	1 form c x 2 [Separate Type]	
Contact Material	Silver oxide complex alloy	
Contact Resistance	4 mΩ typical (measured at 7 A) initial	
Contact Switching Voltage	16 Vdc max. 5 Vdc min.	
Contact Switching Current	30 A max. (at 16 Vdc)	
Contact Carrying Current	35 A (2 minutes max. 12 Vdc at 25°C) 30 A (2 minutes max. 12 Vdc at 85°C) 25 A (2 minutes max. 12 Vdc at 125°C)	
Operate Time	2.5 ms typical (at nominal voltage) initial	
Release Time	3.0 ms typical (at nominal voltage, with diode) initial	
Nominal Operate Power	900 mW	
Insulation Resistance	100 MΩ at 500 Vdc	
Breakdown Voltage	500 Vac min. for 1 minute	
Shock Resistance	98 m/s <sup>2</sup> min. [misoperating]	
Vibration Resistance	10 to 300 Hz, 43 m/s <sup>2</sup> min. [misoperating]	
Ambient Temperature	-40°C to +125°C (-40°F to +257°F)	
Coil Temperature	70°C/W (contact carrying current 0 A)	
Life Expectancy	Mechanical	1 × 10 <sup>6</sup> operations
	Electrical	1 × 10 <sup>5</sup> operations (at 14 Vdc, Motor Load 20 A/3 A)
Weight	Approx. 6.4 g	



- All specifications in this catalog and production status of products are subject to change without notice. Prior to the purchase, please contact NEC Tokin for updated product data.
- Please request for a specification sheet for detailed product data prior to the purchase.
- Before using the product in this catalog, please read "Precautions" and other safety precautions listed in the printed version catalog.

EP1 SERIES

FEATURES

- 33% less relay space than conventional relays (MR301 Series)
- High performance & productivity by unique structure
- Flux tight housing
- Delivered in stick-tube for automatic insertion machine
- Washable type available



PART NUMBERS AND COIL RATINGS

At 20°C (68°F)

Part Number		Nominal Voltage (Vdc)	Coil Resistance ( $\Omega \pm 10\%$ )	Nominal Current (mA)	Must Operate Voltage (Vdc)	Must Release Voltage (Vdc)	Nominal Operate Power (W)
Standard Type	High Current Type						
EP1-3L1	EP1-B3G1	12	225	53.3	6.5	0.9	0.64
EP1-3L2	EP1-B3G2	12	225	53.3	7.0	0.9	0.64
EP1-3L3	EP1-B3G3	12	225	53.3	7.5	0.9	0.64
EP1-4L3	EP1-B4G3	12	300	40.0	7.5	0.9	0.48
EP1-4L4	EP1-B4G4	12	300	40.0	8.0	0.9	0.48
EP1-4L5	EP1-B4G5	12	300	40.0	8.5	0.9	0.48

PART NUMBER SYSTEM

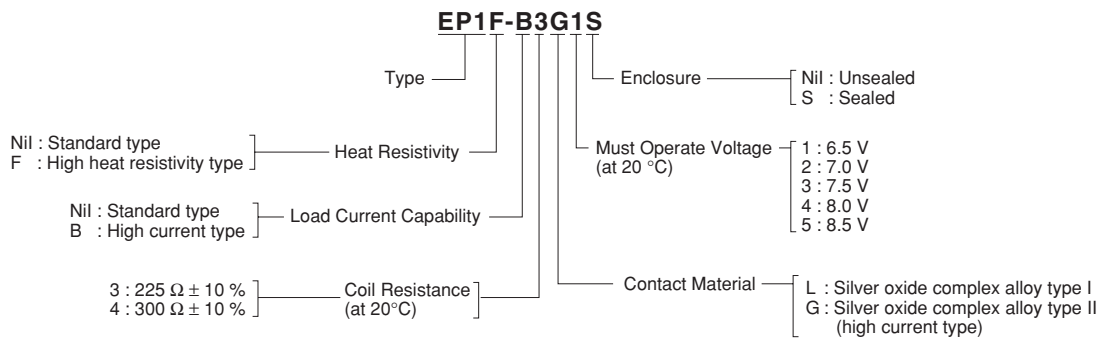

- All specifications in this catalog and production status of products are subject to change without notice. Prior to the purchase, please contact NEC Tokin for updated product data.
- Please request for a specification sheet for detailed product data prior to the purchase.
- Before using the product in this catalog, please read "Precautions" and other safety precautions listed in the printed version catalog.

DIMENSIONS

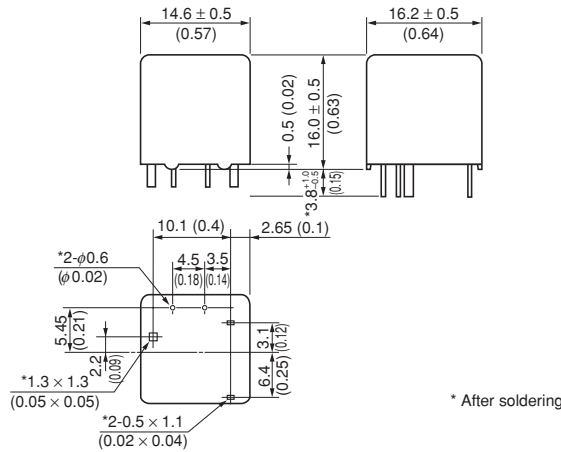

PCB PAD LAYOUT and SCHEMATICS (bottom view) mm (inch)

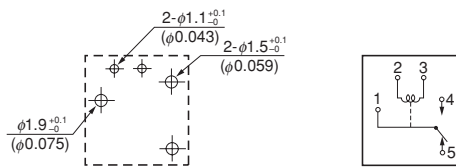

SPECIFICATIONS

At 20°C (68°F)

Items		Specification
Contact Form		1 form C
Contact Material		Silver oxide complex alloy
Contact Resistance		5.2 mΩ typ. (Standard), 3.2 mΩ typ. (High current)
Contact Switching Voltage		16 Vdc max. 5 Vdc min.
Contact Switching Current		25 A max. (at 16 Vdc) 1 A min.
Contact Carrying Current	Standard	30 A max. (2 minutes max.) (at 12 Vdc, 85°C)
	High	35 A max. (2 minutes max.) (at 12 Vdc, 85°C)
Operate Time (Excluding bounce)		10 ms max. (at 12 Vdc) initial
Release Time (Excluding bounce)		10 ms max. (at 12 Vdc) initial
Nominal Operate Power		0.48 W/0.64 W (at 12 Vdc)
Insulation Resistance		100 MΩ min. (at 500 Vdc) initial
Breakdown Voltage		500 Vac min. (for 1 minute) initial
Shock Resistance		98 m/s <sup>2</sup> min. (misoperating)
Vibration Resistance		10 to 300 Hz, 43 m/s <sup>2</sup> min. (misoperating)
Coil Temperature Rise		50°C/W (Contact Carrying Current 0 A)
Ambient Temperature		-40°C to +85°C (-40°F to +185°F)
Life Expectancy	Mechanical	1 × 10 <sup>6</sup> operations
	Electrical	1 × 10 <sup>5</sup> operations (at 14 Vdc, Motor Load 20 A/3 A)
Weight		Approx. 8 g



- All specifications in this catalog and production status of products are subject to change without notice. Prior to the purchase, please contact NEC Tokin for updated product data.
- Please request for a specification sheet for detailed product data prior to the purchase.
- Before using the product in this catalog, please read "Precautions" and other safety precautions listed in the printed version catalog.

**ET1 SERIES**

**FEATURES**

- 50% less relay volume than conventional relay (EP1 Series)
- 75% less relay space than conventional relay (EP1 Series)
- 70% less relay height than conventional relay (EP1 Series)
- 50% less relay weight than conventional relay (EP1 Series)
- Contact switching current of 25A max.
- Flux tight housing
- Delivered in stick-tube for automatic insertion machine
- Washable type available



**PART NUMBERS AND COIL RATINGS**

At 20°C (68°F)

Part Number	Nominal Voltage (Vdc)	Coil Resistance ( $\Omega \pm 10\%$ )	Nominal Current (mA)	Must Operate Voltage (Vdc)	Must Release Voltage (Vdc)	Nominal Operate Power (W)
ET1-B3M1S	12	225	53.3	6.5	0.9	0.64

**PART NUMBER SYSTEM**

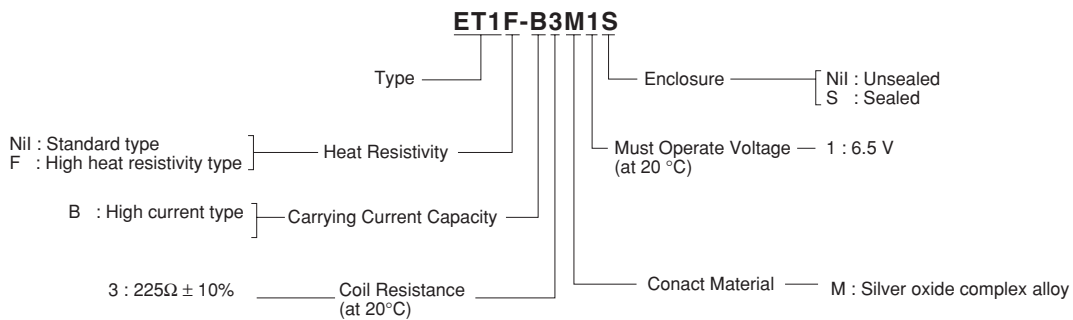

- All specifications in this catalog and production status of products are subject to change without notice. Prior to the purchase, please contact NEC Tokin for updated product data.
- Please request for a specification sheet for detailed product data prior to the purchase.
- Before using the product in this catalog, please read "Precautions" and other safety precautions listed in the printed version catalog.

DIMENSIONS mm (inch)

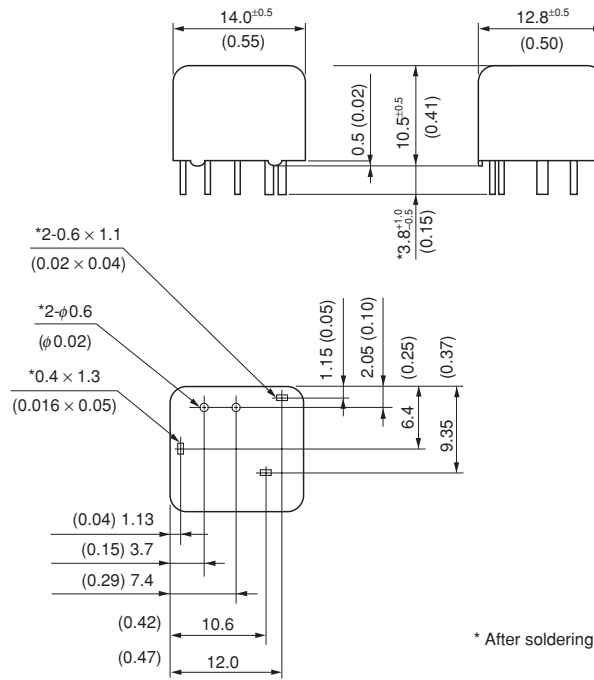

PCB PAD LAYOUT and SCHEMATICS (bottom view) mm (inch)

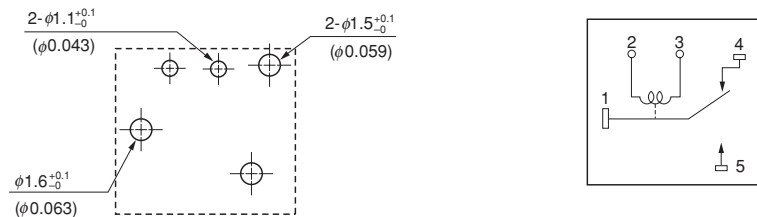

SPECIFICATIONS

At 20°C (68°F)

Items	Specification	
	ET1	ET1F
Contact Form	1 form c	
Contact Material	Silver oxide complex alloy	
Contact Resistance	4 mΩ typical (measured at 7 A) initial	
Contact Switching Voltage	16 Vdc max. 5 Vdc min.	
Contact Switching Current	25 A max. (at 16 Vdc)	
Contact Carrying Current	35 A (2 minutes max. 12 Vdc at 20°C) 30 A (2 minutes max. 12 Vdc at 85°C)	40 A (2 minutes max. 12 Vdc at 20°C) 35 A (2 minutes max. 12 Vdc at 85°C) 30 A (2 minutes max. 12 Vdc at 125°C)
Operate Time	2.5 ms typical (at nominal voltage) initial	
Release Time	3.0 ms typical (at nominal voltage. with diode) initial	
Nominal Operate Power	640 mW	
Insulation Resistance	100 MΩ min. at 500 Vdc	
Breakdown Voltage	500 Vac min. for 1 minute	
Shock Resistance	98 m/s <sup>2</sup> min. [misoperating]	
Vibration Resistance	10 to 300 Hz, 43 m/s <sup>2</sup> min. [misoperating]	
Ambient Temperature	-40°C to +85°C (-40°F to +185°F)	-40°C to +125°C (-40°F to +257°F)
Coil Temperature Rise	70°C/W (contact carrying current 0 A)	
Life Expectancy	Mechanical	1 × 10 <sup>6</sup> operations
	Electrical	1 × 10 <sup>5</sup> operations (at 14 Vdc, Motor Load 20 A/3 A)
Weight	Approx. 7.5 g	



- All specifications in this catalog and production status of products are subject to change without notice. Prior to the purchase, please contact NEC Tokin for updated product data.
- Please request for a specification sheet for detailed product data prior to the purchase.
- Before using the product in this catalog, please read "Precautions" and other safety precautions listed in the printed version catalog.

**EX1 Series**

**FEATURES**

- 65% less relay volume than conventional relay (ET1 Series)
- 50% less relay space than conventional relay (ET1 Series)
- 78% less relay weight than conventional relay (ET1 Series)
- Contact switching current of 30A max.
- Flux tight housing
- Delivered in stick-tube for automatic insertion machine
- Washable type available
- Reflowable type available



**PART NUMBERS AND COIL RATINGS**

At 20°C (68°F)

Part Number	Nominal Voltage (Vdc)	Coil Resistance ( $\Omega \pm 10\%$ )	Nominal Current (mA)	Must Operate Voltage (Vdc)	Must Release Voltage (Vdc)	Nominal Operate Power (W)
EX1-2U1S	12	160	75	6.5	0.9	0.9

**PART NUMBER SYSTEM**

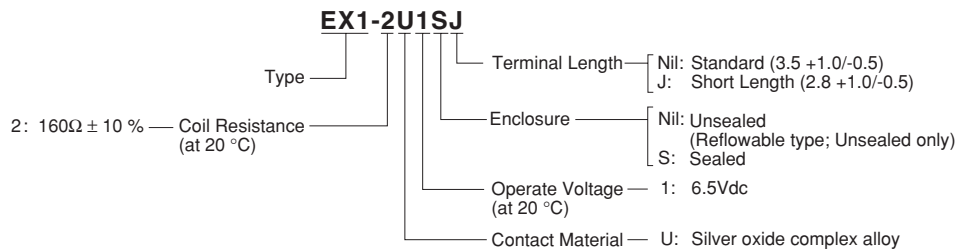

- All specifications in this catalog and production status of products are subject to change without notice. Prior to the purchase, please contact NEC Tokin for updated product data.
- Please request for a specification sheet for detailed product data prior to the purchase.
- Before using the product in this catalog, please read "Precautions" and other safety precautions listed in the printed version catalog.

DIMENSIONS mm (inch)

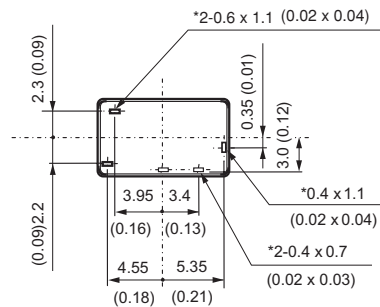
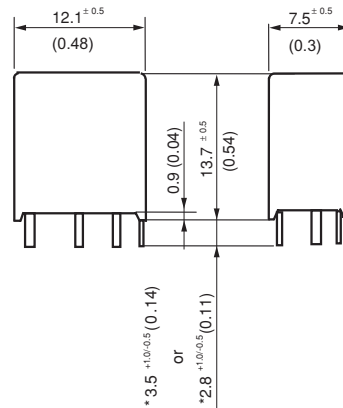

PCB PAD LAYOUT and SCHEMATICS (bottom view) mm (inch)

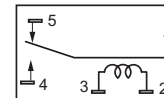
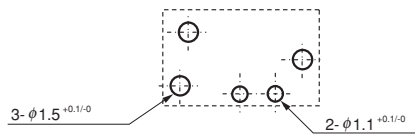

SPECIFICATIONS

At 20°C (68°F)

Items	Specification	
Contact Form	1 form c	
Contact Material	Silver oxide complex alloy	
Contact Resistance	4 mΩ typical (measured at 7 A) initial	
Contact Switching Voltage	16 Vdc max. 5 Vdc min.	
Contact Switching Current	30 A max. (at 16 Vdc)	
Contact Carrying Current	35 A (2 minutes max. 12 Vdc at 25°C) 30 A (2 minutes max. 12 Vdc at 85°C) 25 A (2 minutes max. 12 Vdc at 125°C)	
Operate Time	2.5 ms typical (at nominal voltage) initial	
Release Time	3.0 ms typical (at nominal voltage. with diode) initial	
Nominal Operate Power	900 mW	
Insulation Resistance	100 MΩ at 500 Vdc	
Breakdown Voltage	500 Vac min. for 1 minute	
Shock Resistance	98 m/s <sup>2</sup> min. [misoperating]	
Vibration Resistance	10 to 300 Hz, 43 m/s <sup>2</sup> min. [misoperating]	
Ambient Temperature	-40°C to +125°C (-40°F to +257°F)	
Coil Temperature	70°C/W (contact carrying current 0 A)	
Life Expectancy	Mechanical	1 × 10 <sup>6</sup> operations
	Electrical	1 × 10 <sup>5</sup> operations (at 14 Vdc, Motor Load 20 A/3 A)
Weight	Approx. 3.5 g	



- All specifications in this catalog and production status of products are subject to change without notice. Prior to the purchase, please contact NEC Tokin for updated product data.
- Please request for a specification sheet for detailed product data prior to the purchase.
- Before using the product in this catalog, please read "Precautions" and other safety precautions listed in the printed version catalog.



DIMENSIONS mm (inch)

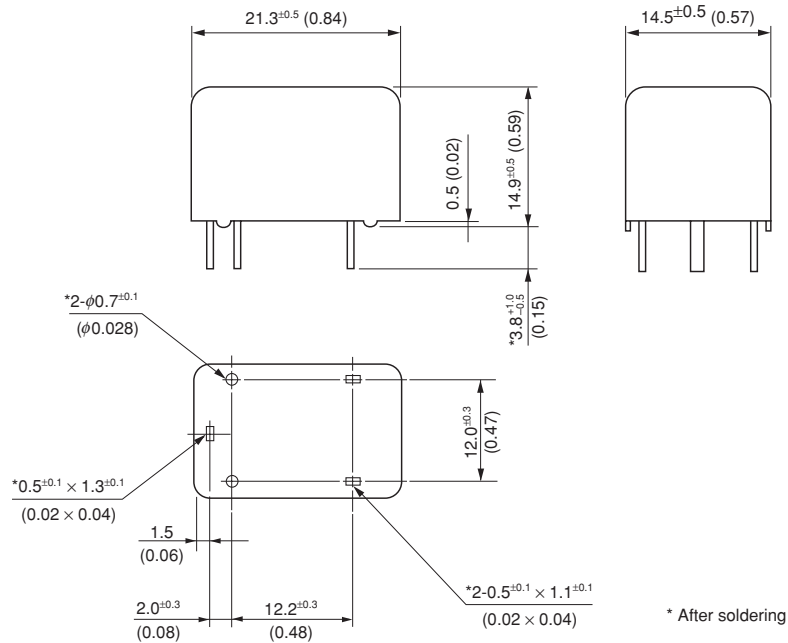

PCB PAD LAYOUT and SCHEMATICS (bottom view) mm (inch)

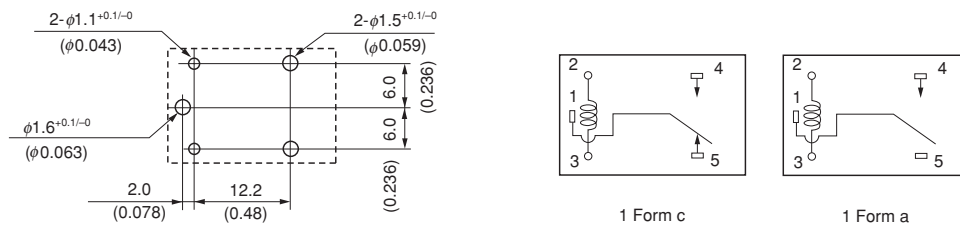

SPECIFICATIONS

At 20°C (68°F)

Items	Specification			
	EQ1-31000S	EQ1-11040S	EQ1-11111S	EQ1-22111S
Contact Form	1 form c		1 form a	
Contact Material	Silver oxide complex alloy			
Contact Resistance	5 m $\Omega$ typical (measured at 1 A) initial			
Contact Switching Voltage	16 Vdc max. 5 Vdc min.			
Contact Switching Current	30 A max. (at 16 Vdc)			
Contact Carrying Current (2 minutes max.)	40 A (12 Vdc at 25°C)	35 A (12 Vdc at 25°C)	30 A (12 Vdc at 85°C)	
Operate Time	3 ms typical (at nominal voltage) initial			
Release Time	4 ms typical (at nominal voltage. with diode) initial			
Nominal Operate Power	640 mW	1000 mW		800 mW
Insulation Resistance	100 M $\Omega$ at 500 Vdc			
Breakdown Voltage	500 Vac min. for 1 minute			
Shock Resistance	98 m/s <sup>2</sup> min. [misoperating]			
Vibration Resistance	10 to 300 Hz, 43 m/s <sup>2</sup> min. [misoperating]			
Ambient Temperature	-40°C to +85°C (-40°F to +185°F)		-40°C to +125°C (-40°F to +257°F)	
Coil Temperature	70°C/W (contact carrying current 0 A)			
Life Expectancy	Mechanical	1 × 10 <sup>6</sup> operations		
	Electrical	1 × 10 <sup>5</sup> operations (at 14 Vdc, motor load 20 A/3 A)		1 × 10 <sup>5</sup> operations (at 14 Vdc. Lamp load 120 W)
Weight	Approx. 9 g			



- All specifications in this catalog and production status of products are subject to change without notice. Prior to the purchase, please contact NEC Tokin for updated product data.
- Please request for a specification sheet for detailed product data prior to the purchase.
- Before using the product in this catalog, please read "Precautions" and other safety precautions listed in the printed version catalog.

**NOTICE**

**(1) Capacitive load**

If the load is capacitive, an inrush current to charge the load with poses a problem. In this case, a current-limiting resistor or surge suppressor coil is connected in series to the contacts to suppress the peak current.

**(2) Clinching terminals**

To secure the relay temporarily to a printed circuit board for soldering, particular terminals are allowed to be clinched within a particular angle, other terminals, never clinched.

The terminal numbers and the angle for clinching of each series are as follows.

- 1) No. 4 and no. 5 terminals to 45° maximum for H bridge type of EN2, EP2 and ET2
- 2) No. 5 and no. 9 terminals to 45° maximum for separate type of EN2 and EP2
- 3) No. 4 and no. 5 terminals to 45° maximum for EP1 and ET1
- 4) No. 1, 4 and no. 5 terminals to 45° maximum for EQ1

**(3) Drive circuit**

Since the coil of a relay has an inductive impedance, a counter electromotive force is generated when the circuit is opened. This voltage may damage the relay drive IC. Therefore, a diode is connected in parallel with the coil, as shown in Figure 1.

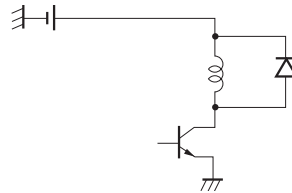
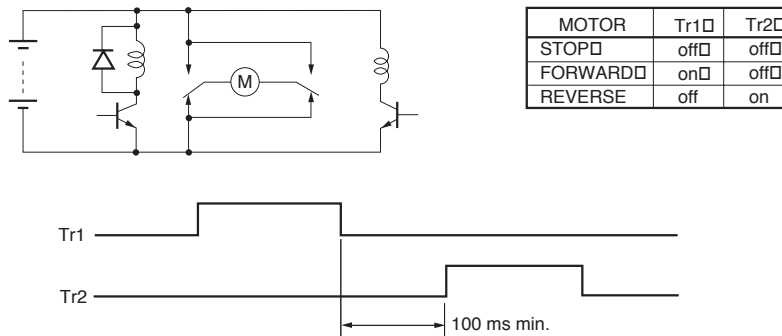

Figure 1

**(4) Typical application for EN2, EP2 and ET2 relays (H bridge type)**



- All specifications in this catalog and production status of products are subject to change without notice. Prior to the purchase, please contact NEC Tokin for updated product data.
- Please request for a specification sheet for detailed product data prior to the purchase.
- Before using the product in this catalog, please read "Precautions" and other safety precautions listed in the printed version catalog.

APPLICATIONS

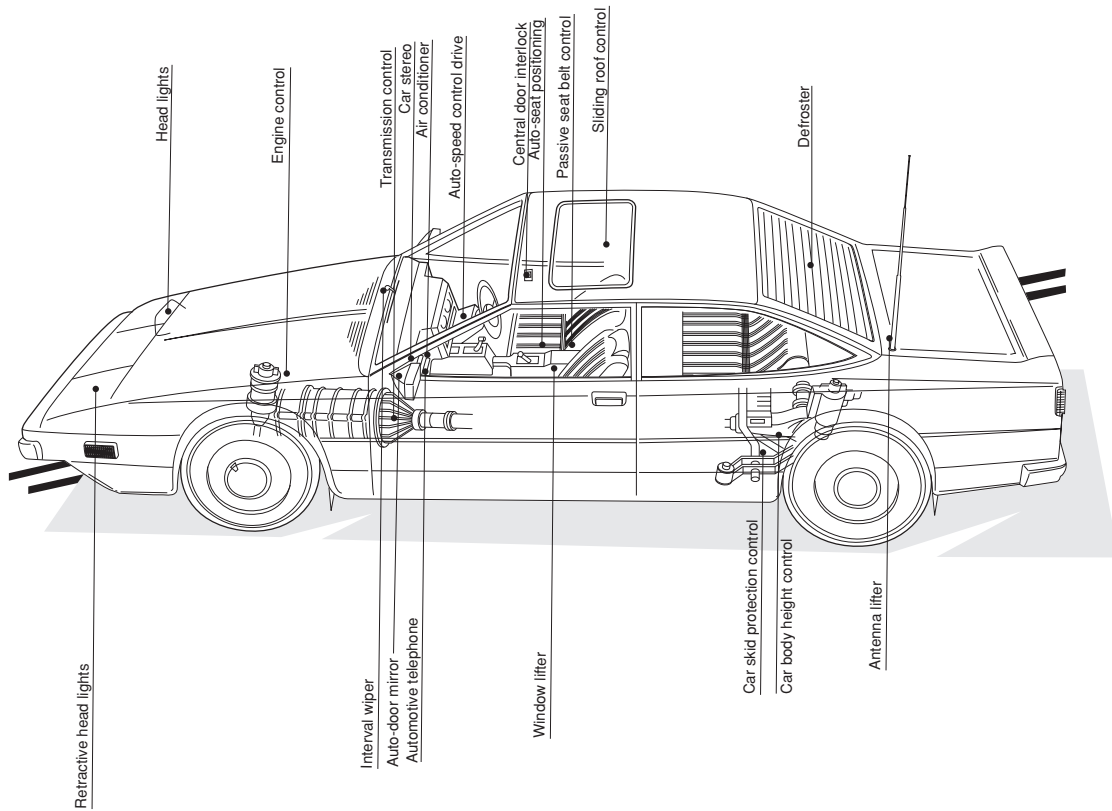

- All specifications in this catalog and production status of products are subject to change without notice. Prior to the purchase, please contact NEC Tokin for updated product data.
- Please request for a specification sheet for detailed product data prior to the purchase.
- Before using the product in this catalog, please read "Precautions" and other safety precautions listed in the printed version catalog.

No part of this document may be copied or reproduced in any form or by any means without the prior written consent of NEC/TOKIN Corporation. NEC/TOKIN Corporation assumes no responsibility for any errors which may appear in this document.

NEC/TOKIN Corporation does not assume any liability for infringement of patents, copyrights or other intellectual property rights of third parties by or arising from use of a device described herein or any other liability arising from use of such device. No license, either express, implied or otherwise, is granted under any patents, copyrights or other intellectual property rights of NEC/TOKIN Corporation or others.

While NEC/TOKIN Corporation has been making continuous effort to enhance the reliability of its electronic components, the possibility of defects cannot be eliminated entirely. To minimize risks of damage or injury to persons or property arising from a defect in an NEC/TOKIN electronic component, customers must incorporate sufficient safety measures in its design, such as redundancy, fire-containment, and anti-failure features. NEC/TOKIN devices are classified into the following three quality grades:

"Standard," "Special," and "Specific". The Specific quality grade applies only to devices developed based on a customer designated "quality assurance program" for a specific application. The recommended applications of a device depend on its quality grade, as indicated below. Customers must check the quality grade of each device before using it in a particular application.

Standard: Computers, office equipment, communications equipment, test and measurement equipment, audio and visual equipment, home electronic appliances, machine tools, personal electronic equipment and industrial robots

Special: Transportation equipment (automobiles, trains, ships, etc.), traffic control systems, anti-disaster systems, anti-crime systems, safety equipment and medical equipment (not specifically designed for life support)

Specific: Aircrafts, aerospace equipment, submersible repeaters, nuclear reactor control systems, life support systems or medical equipment for life support, etc.

The quality grade of NEC/TOKIN devices is "Standard" unless otherwise specified in NEC/TOKIN's Data Sheets or Data Books. If customers intend to use NEC/TOKIN devices for applications other than those specified for Standard quality grade, they should contact an NEC/TOKIN sales representative in advance.

(Note)

- (1) "NEC/TOKIN" as used in this statement means NEC/TOKIN Corporation and also includes its majority-owned subsidiaries.
- (2) "NEC/TOKIN electronic component products" means any electronic component product developed or manufactured by or for NEC/TOKIN (as defined above).

DE0202



- All specifications in this catalog and production status of products are subject to change without notice. Prior to the purchase, please contact NEC Tokin for updated product data.
- Please request for a specification sheet for detailed product data prior to the purchase.
- Before using the product in this catalog, please read "Precautions" and other safety precautions listed in the printed version catalog.