

Information

NEC/TOKIN

Miniature Signal Relays

MR82 Series

Technical data

© NEC/TOKIN Corporation 2006



- All specifications in this catalog and production status of products are subject to change without notice. Prior to the purchase, please contact NEC Tokin for updated product data.
- Please request for a specification sheet for detailed product data prior to the purchase.
- Before using the product in this catalog, please read "Precautions" and other safety precautions listed in the printed version catalog.

[MEMO]

2



- All specifications in this catalog and production status of products are subject to change without notice. Prior to the purchase, please contact NEC Tokin for updated product data.
- Please request for a specification sheet for detailed product data prior to the purchase.
- Before using the product in this catalog, please read "Precautions" and other safety precautions listed in the printed version catalog.

The information in this document is based on documents issued in March, 2006 at the latest.

The information is subject to change without notice. For actual design-in refer to the latest publications of data sheet, etc., for the most up-date specifications of the device.

No part of this document may be copied or reproduced in any form or by any means without the prior written consent of NEC/TOKIN Corporation. NEC/TOKIN Corporation assumes no responsibility for any errors which may appear in this document.

NEC/TOKIN Corporation does not assume any liability for infringement of patents, copyrights or other intellectual property rights of third parties by or arising from use of a device described herein or any other liability arising from use of such device. No license, either express, implied or otherwise, is granted under any patents, copyrights or other intellectual property rights of NEC/TOKIN Corporation or others.

While NEC/TOKIN Corporation has been making continuous effort to enhance the reliability of its electronic components, the possibility of defects cannot be eliminated entirely. To minimize risks of damage or injury to persons or property arising from a defect in an NEC/TOKIN electronic component, customers must incorporate sufficient safety measures in its design, such as redundancy, fire-containment, and anti-failure features. NEC/TOKIN devices are classified into the following three quality grades:

"Standard," "Special," and "Specific". The Specific quality grade applies only to devices developed based on a customer designated "Quality assurance program" for a specific application. The recommended applications of a device depend on its quality grade, as indicated below. Customers must check the quality grade of each device before using it in a particular application.

Standard: Computers, office equipment, communications equipment, test and measurement equipment, audio and visual equipment, home electronic appliances, machine tools, personal electronic equipment and industrial robots

Special: Transportation equipment (automobiles, trains, ships, etc.), traffic control systems, anti-disaster systems, anti-crime systems, safety equipment and medical equipment (not specifically designed for life support)

Specific: Aircrafts, aerospace equipment, submersible repeaters, nuclear reactor control systems, life support systems or medical equipment for life support, etc.

The quality grade of NEC/TOKIN devices is "Standard" unless otherwise specified in NEC/TOKIN's Data Sheets or Data Books. If customers intend to use NEC/TOKIN devices for applications other than those specified for Standard quality grade, they should contact an NEC/TOKIN sales representative in advance.

(Note)

- (1) "NEC/TOKIN" as used in this statement means NEC/TOKIN Corporation and also includes its majority-owned subsidiaries.
- (2) "NEC/TOKIN electronic component products" means any electronic component product developed or manufactured by or for NEC/TOKIN (as defined above).

DE0102

3



- All specifications in this catalog and production status of products are subject to change without notice. Prior to the purchase, please contact NEC Tokin for updated product data.
- Please request for a specification sheet for detailed product data prior to the purchase.
- Before using the product in this catalog, please read "Precautions" and other safety precautions listed in the printed version catalog.

[MEMO]

4



- All specifications in this catalog and production status of products are subject to change without notice. Prior to the purchase, please contact NEC Tokin for updated product data.
- Please request for a specification sheet for detailed product data prior to the purchase.
- Before using the product in this catalog, please read "Precautions" and other safety precautions listed in the printed version catalog.

CONTENTS

1. Preface	7
2. Structure	8
3. Basic Characteristics	9
3.1 Switching power	9
3.2 Coil temperature rise	9
3.3 Driving power vs. timing	10
3.4 Magnetic interference	11
4. Distribution of Characteristics	12
4.1 Operate & release voltages	12
4.2 Operate & release times	12
4.3 Transfer time	13
4.4 Timing and details	14
4.5 Contact resistance	18
4.6 Breakdown voltage	18
5. Test Data	19
5.1 Environmental tests	20
5.1.1 High-temperature test	20
5.1.2 Low-temperature test	21
5.1.3 Moisture resistance test	22
5.1.4 Heat shock test	23
5.1.5 Vibration test	24
5.1.6 Shock test	25
5.2 Contact life tests	26
5.2.1 Non-load test	26
5.2.2 Resistive load test A	27
5.2.3 Resistive load test B	28



- All specifications in this catalog and production status of products are subject to change without notice. Prior to the purchase, please contact NEC Tokin for updated product data.
- Please request for a specification sheet for detailed product data prior to the purchase.
- Before using the product in this catalog, please read "Precautions" and other safety precautions listed in the printed version catalog.

[MEMO]

6



- All specifications in this catalog and production status of products are subject to change without notice. Prior to the purchase, please contact NEC Tokin for updated product data.
- Please request for a specification sheet for detailed product data prior to the purchase.
- Before using the product in this catalog, please read "Precautions" and other safety precautions listed in the printed version catalog.

1. Preface

Miniature signal relays are used in a wide range of application fields including communication, measurement, and factory automation. This document gives the basic characteristics and test data of NEC/TOKIN's MR82 series miniature signal relays.

- Notes 1.** The symbol \top shown in the graphs throughout this document indicates the maximum value of the data. Likewise, \perp indicates the minimum value, and ϕ (*) indicates the mean value.
- 2.** When a relay is driven by an IC, a protective element such as a diode may be connected in parallel with the relay coil to protect the IC from damage caused by the counter-electromotive force (EMF) due to the inductance of the coil. However, unless otherwise specified, the operate time and release time (set and reset times) shown in this document are measured without such a protective element.

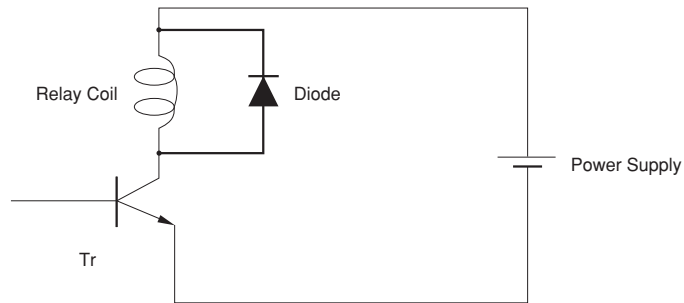

For Right Use of Miniature Relays

DO NOT EXCEED MAXIMUM RATINGS.

Do not use relays under exceeding conditions such as over ambient temperature, over voltage and over current. Incorrect use could result in malfunctioning, abnormal heating, or cause burning.

READ CAUTIONS IN THE SELECTION GUIDE.

Read the cautions described in NEC/TOKIN's "Miniature Relays" (0123EMDD03VOL01E) when you choose relays for your application.



- All specifications in this catalog and production status of products are subject to change without notice. Prior to the purchase, please contact NEC Tokin for updated product data.
- Please request for a specification sheet for detailed product data prior to the purchase.
- Before using the product in this catalog, please read "Precautions" and other safety precautions listed in the printed version catalog.

2. Structure

Figure 2.1 shows the structure and parts of the MR82 series relay.

Figure 2.1 Structure of the MR82 Series Relay

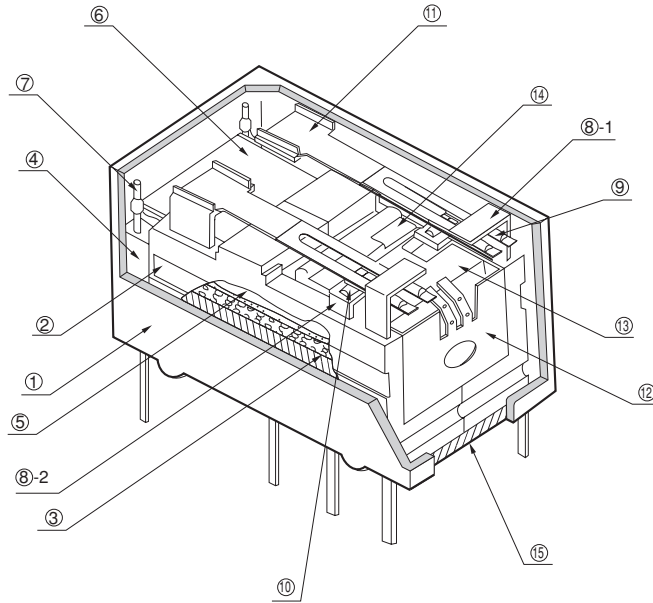

Table 2.1 Parts of the MR82 Series Relay

No.	Parts	Material
1	Cover	Polybutylene telephthalate#
2	Housing mold	Polybutylene telephthalate#
3	Coil wire	Polyurethane copper wire
4	Spool	Polybutylene telephthalate#
5	Core	Pure iron
6	Yoke	Pure iron
7	Coil terminal	Nickel silver
⑧-1	Stationary contact terminal (Make Contact)	Phosphor bronze
⑧-2	Stationary contact terminal (Break contact)	Phosphor bronze
9	Moving contact	Au-alloy + AgNi
10	Stationary contact	Au-alloy + AgNi
11	Contact spring	Phosphor bronze
12	Restoring spring	Phosphor bronze
13	Armature	Pure iron
14	Armature block mold	Polyacetal*
15	Sealing material	Epoxy resin

Note # : Conforms to UL94V-0

* : Conforms to UL94HB



- All specifications in this catalog and production status of products are subject to change without notice. Prior to the purchase, please contact NEC Tokin for updated product data.
- Please request for a specification sheet for detailed product data prior to the purchase.
- Before using the product in this catalog, please read "Precautions" and other safety precautions listed in the printed version catalog.

3. Basic Characteristics

The section provides data necessary for designing a circuit that uses the relay.

3.1 Switching power

If the contact load voltage and current of the relay are in the region enclosed by the solid and dotted lines in the figure below, the relay can perform stable switching operation. If the relay is used at a voltage or current exceeding this region, the life of the contacts may be significantly shortened.

Figure 3.1 Switching Power

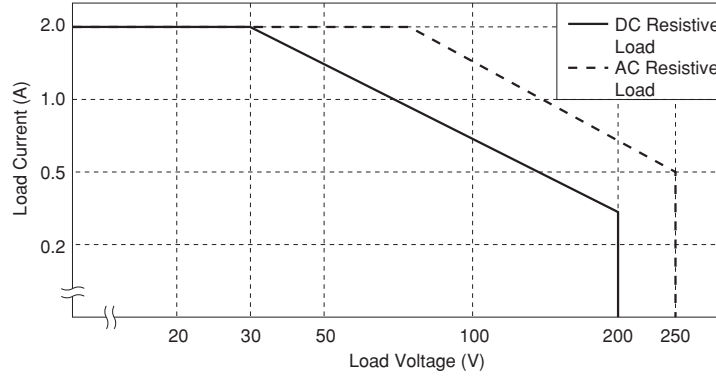

3.2 Coil temperature rise

Figure 3.2 shows the relation between the rise in coil temperature and the power (product of the coil voltage and current) dissipated by the coil. This figure shows the difference between the temperature before the power is applied to the coil and the saturated temperature after application of power to the coil.

Figure 3.2 Coil Temperature Rise

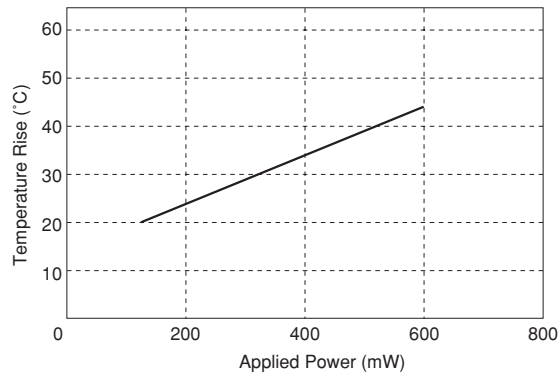

- All specifications in this catalog and production status of products are subject to change without notice. Prior to the purchase, please contact NEC Tokin for updated product data.
- Please request for a specification sheet for detailed product data prior to the purchase.
- Before using the product in this catalog, please read "Precautions" and other safety precautions listed in the printed version catalog.

3.3 Driving power vs. timing

Figure 3.3 shows the relations among the power applied to drive the relay, the operate time, and the release time.

Figure 3.3 Driving Power vs. Timing

(1) Operate time

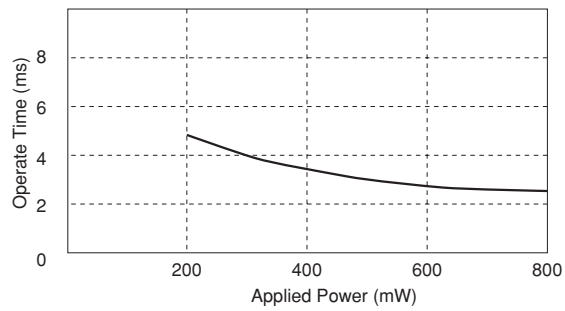

(2) Release time

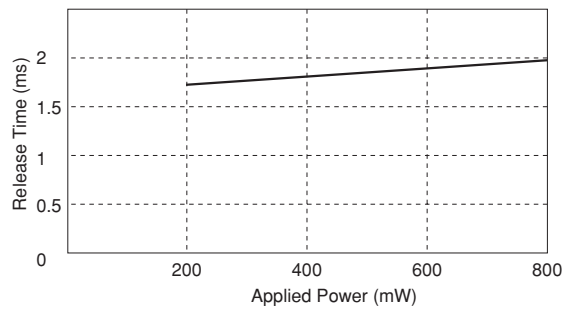

(3) Release time (with diode)

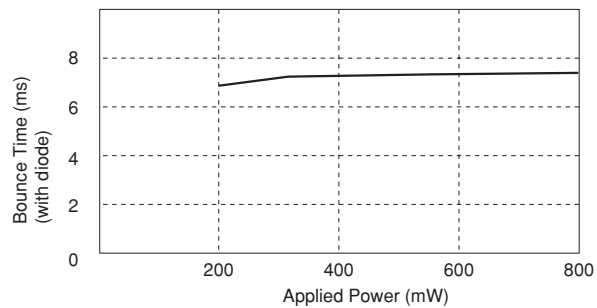

- All specifications in this catalog and production status of products are subject to change without notice. Prior to the purchase, please contact NEC Tokin for updated product data.
- Please request for a specification sheet for detailed product data prior to the purchase.
- Before using the product in this catalog, please read "Precautions" and other safety precautions listed in the printed version catalog.

3.4 Magnetic interference

This section describes changes in the operate voltage caused by mutual magnetic interference when several relays are closely mounted on a printed circuit board (PCB). Figure 3.4 (1) shows the distance among the relays mounted on the PCB. As shown, the pin pitch of each relay is 2.54 mm. Figure 3.4 (2) shows the relay that is subject to interference. In this figure, the hatched relay shown in the center of each relay arrangement is subject to interference, and the surrounding relays influence the center relay. The condition under which the center relay suffers interference and the surrounding relays affect the center relay differs depending on whether power is supplied to each relay. Figure 3.4 (3) shows the deviation in percent of the operate and release voltages of the center relays in Figure 3.4 (2).

Figure 3.4 Magnetic Interference

(1) Mounting pitch (mm)

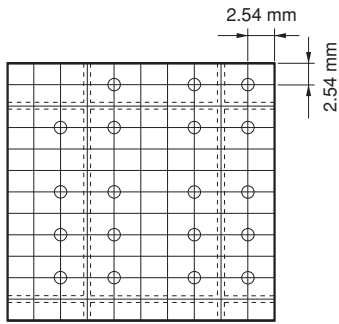

(2) Relay arrangement

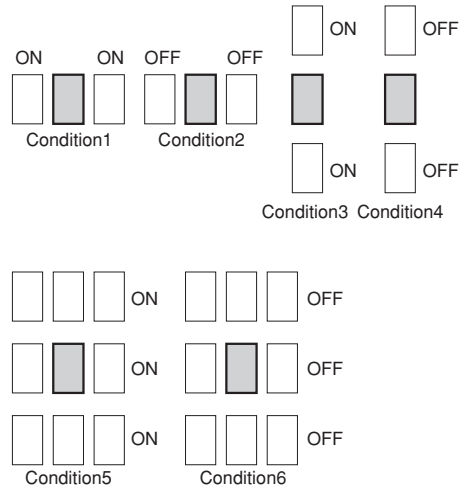

(3) Deviation of must operate and must release voltages

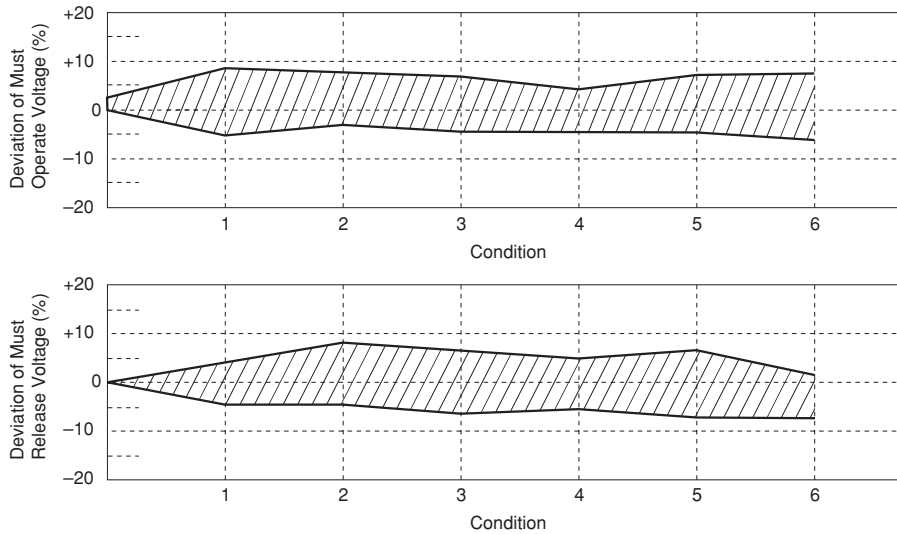

- All specifications in this catalog and production status of products are subject to change without notice. Prior to the purchase, please contact NEC Tokin for updated product data.
- Please request for a specification sheet for detailed product data prior to the purchase.
- Before using the product in this catalog, please read "Precautions" and other safety precautions listed in the printed version catalog.

4. Distribution of Characteristics

This chapter presents the distribution data of the general characteristic values of the MR82 series relay.

The data shown in this chapter are sampled from a certain production lot, and do not necessarily guarantee the characteristics of any particular lot that is shipped.

4.1 Operate & release voltages

This section shows the distribution of the voltage at which the relay operates.

The number of samples is 50 relays for each test.

Figure 4.1 Operate & Release Voltages

12 V type (MR82-12USR)

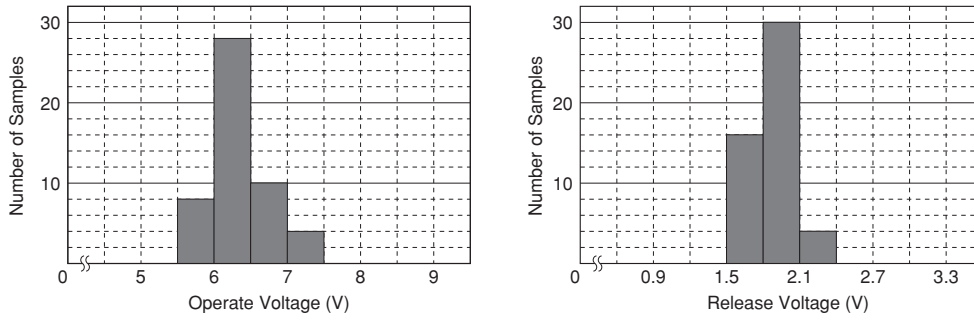

4.2 Operate & release times

This section shows the operate time that elapses from the time when the relay coil is energized until the relay contacts close, and the release time that elapses from the time when the relay coil is deenergized until the closed contacts open.

The number of samples used for each measurement is 20.

Figure 4.2 Operate & Release Times

4.5 V type (MR82-4.5USR)

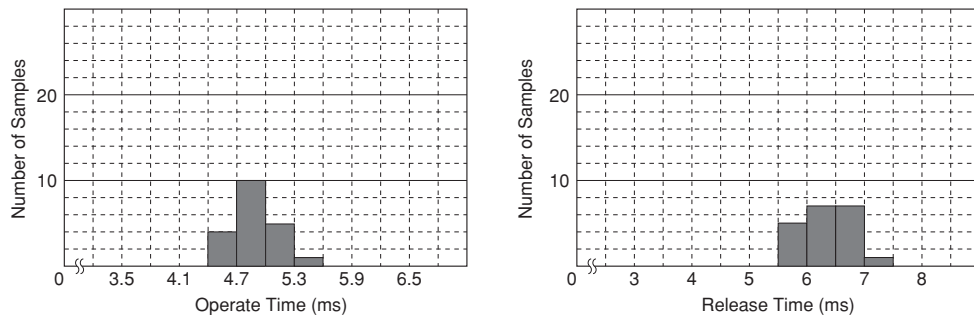

- All specifications in this catalog and production status of products are subject to change without notice. Prior to the purchase, please contact NEC Tokin for updated product data.
- Please request for a specification sheet for detailed product data prior to the purchase.
- Before using the product in this catalog, please read "Precautions" and other safety precautions listed in the printed version catalog.

4.3 Transfer time

This section gives data on the transfer time, which is the total time between the breaking of one set of contacts and the making of another.

The number of samples used for each measurement of the transfer time is 20.

Figure 4.3 Transfer Times

4.5 V type (MR82-4.5USR)

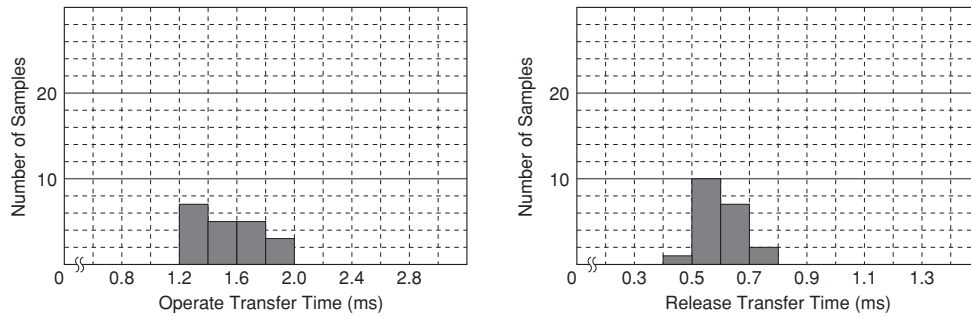

- All specifications in this catalog and production status of products are subject to change without notice. Prior to the purchase, please contact NEC Tokin for updated product data.
- Please request for a specification sheet for detailed product data prior to the purchase.
- Before using the product in this catalog, please read "Precautions" and other safety precautions listed in the printed version catalog.

4.4 Timing and details

The MR82 series relays have two sets of transfer contacts. This section shows the movements of each contact, which are not included in the timing specifications, using the timing chart shown in Figure 4.4 A.

Figure 4.4A Timing Chart of Coil and Contacts

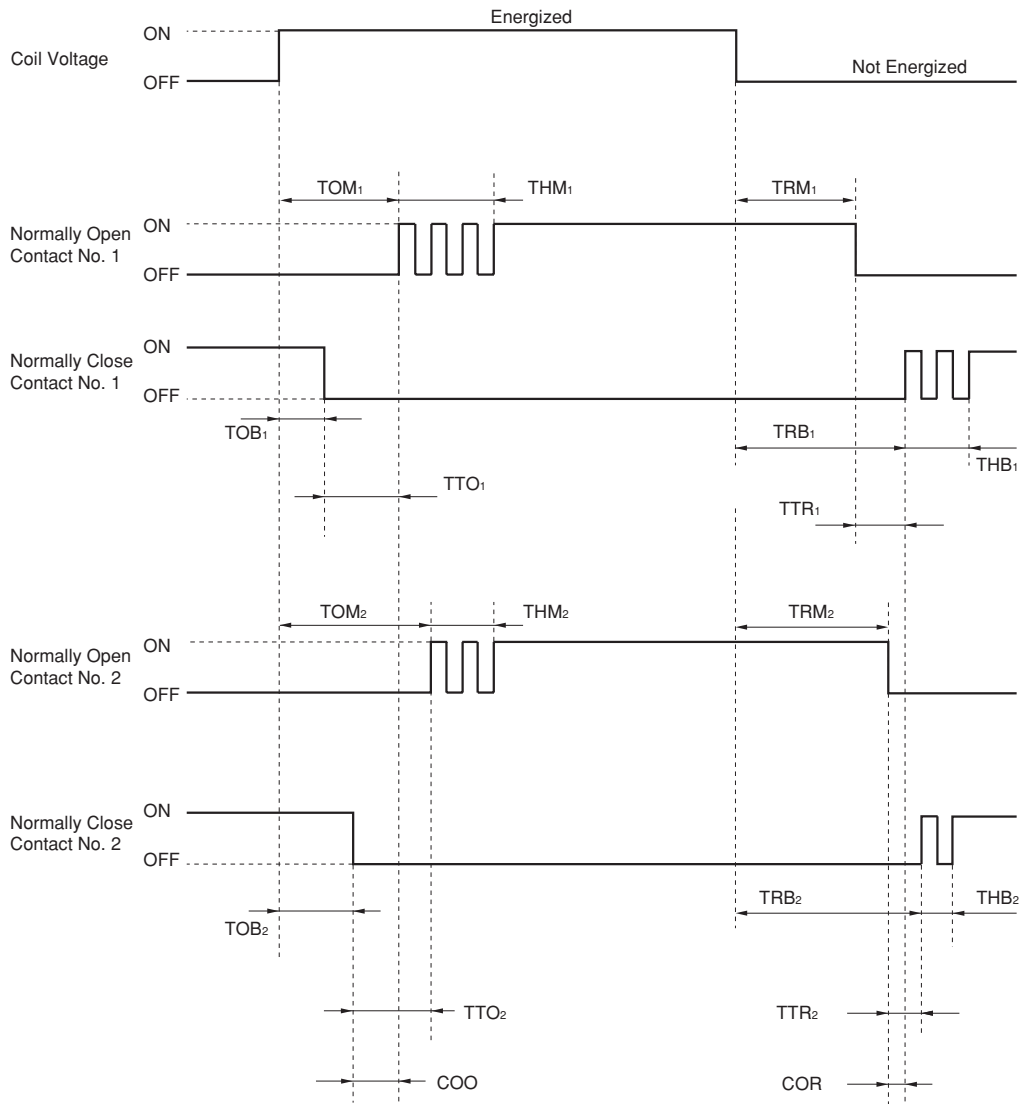

(Test results)

The timing specifications show the greater of the values of the two sets of contacts. The time difference between the two contact sets, however, is almost negligible as shown in data (1) through (8) on the following pages. Practically, therefore, the time difference can be ignored.



- All specifications in this catalog and production status of products are subject to change without notice. Prior to the purchase, please contact NEC Tokin for updated product data.
- Please request for a specification sheet for detailed product data prior to the purchase.
- Before using the product in this catalog, please read "Precautions" and other safety precautions listed in the printed version catalog.

The following charts show the distribution of timing. Twenty MR82-4.5USR's are used as the samples.

Figure 4.4B Timing

(1) On times of make contacts at operation (TOM)

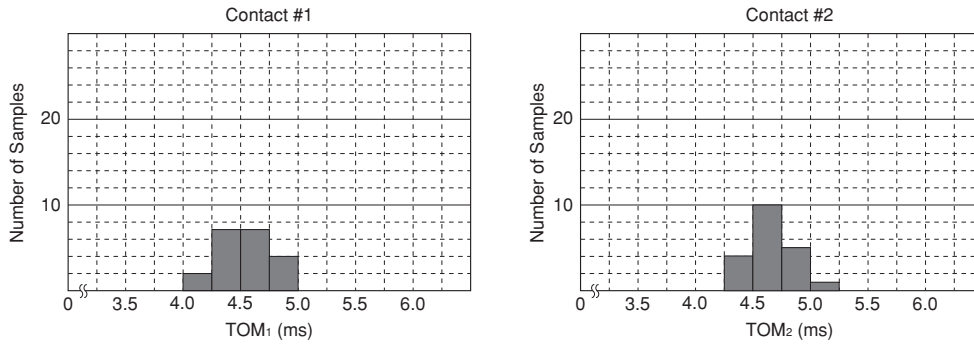

(2) Off times of break contacts at operation (TOB)

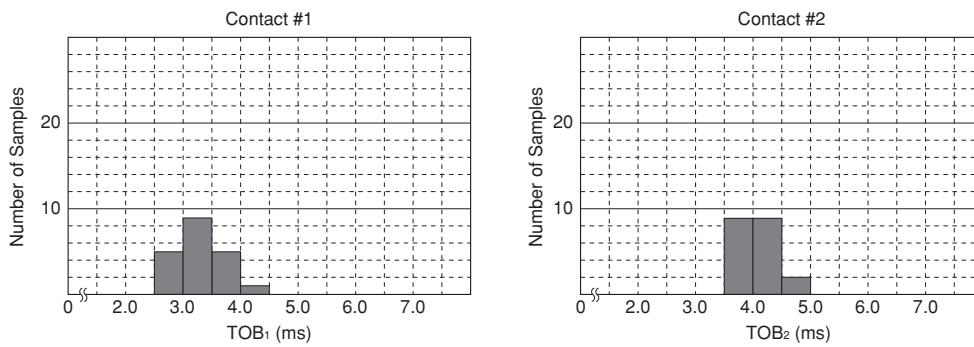

(3) Off times of make contacts at release (TRM)

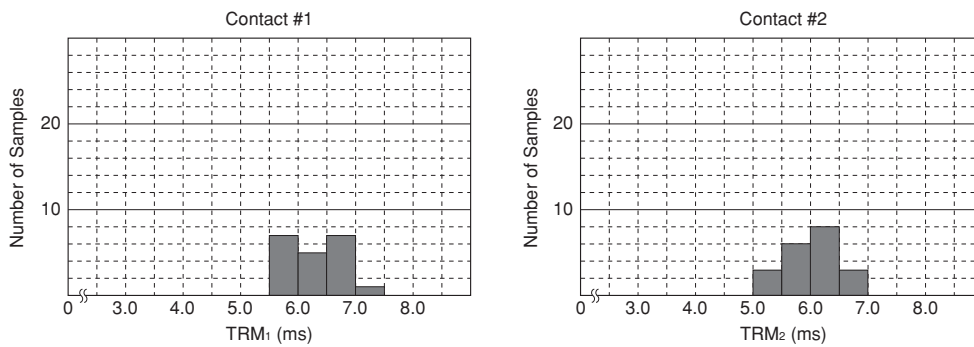

- All specifications in this catalog and production status of products are subject to change without notice. Prior to the purchase, please contact NEC Tokin for updated product data.
- Please request for a specification sheet for detailed product data prior to the purchase.
- Before using the product in this catalog, please read "Precautions" and other safety precautions listed in the printed version catalog.

Figure 4.4C Timing

(4) On times of break contacts at release (TRB)

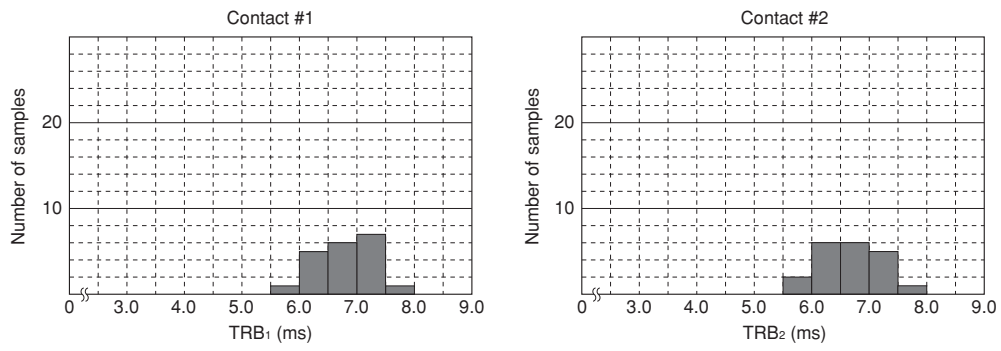

(5) Bounce times of make contacts at operation (THM)

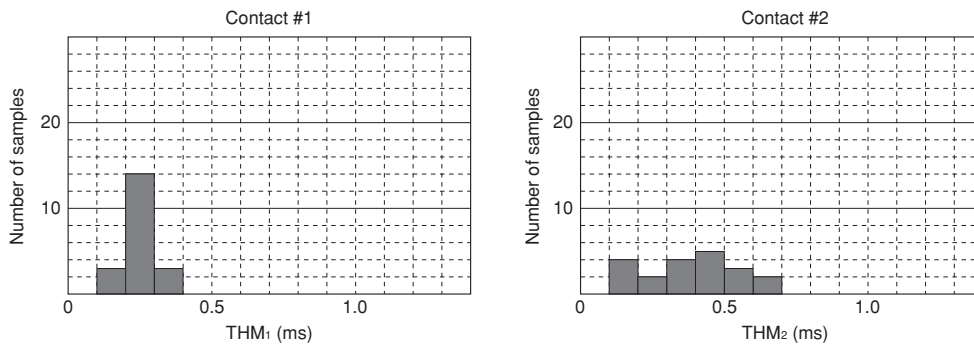

(6) Bounce times of break contacts at release (THB)

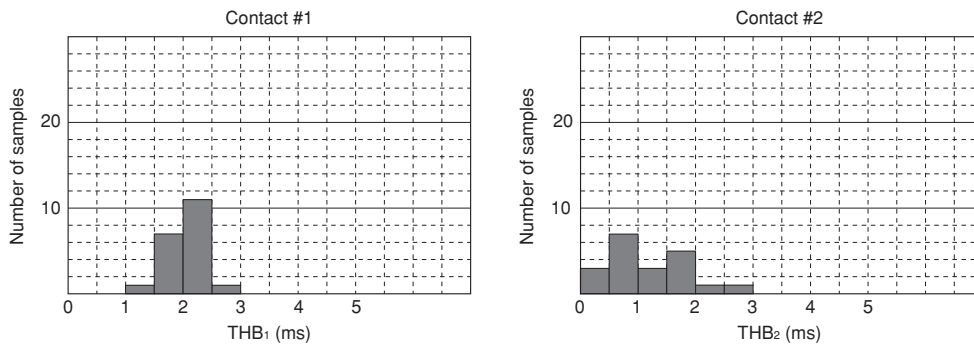

● All specifications in this catalog and production status of products are subject to change without notice. Prior to the purchase, please contact NEC Tokin for updated product data.
 ● Please request for a specification sheet for detailed product data prior to the purchase.
 ● Before using the product in this catalog, please read "Precautions" and other safety precautions listed in the printed version catalog.

Figure 4.4D Timing

(7) Operate transfer times (TTO)

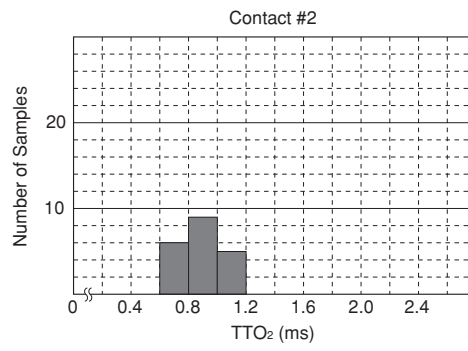
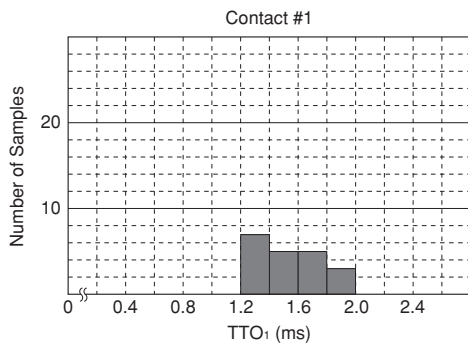

(8) Release transfer times (TTR)

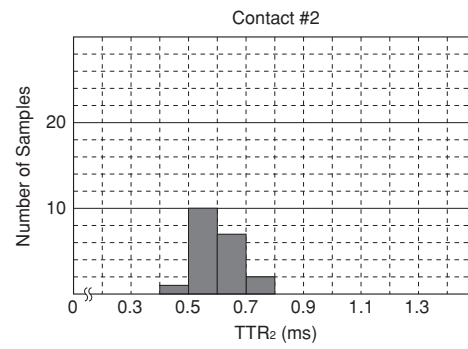
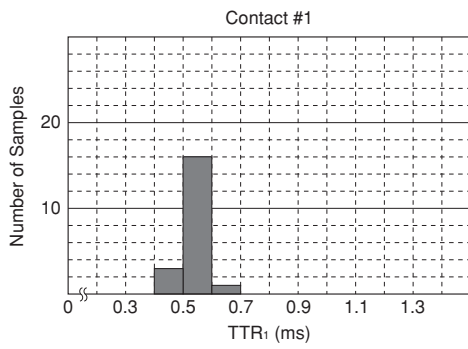

(9) Common open times

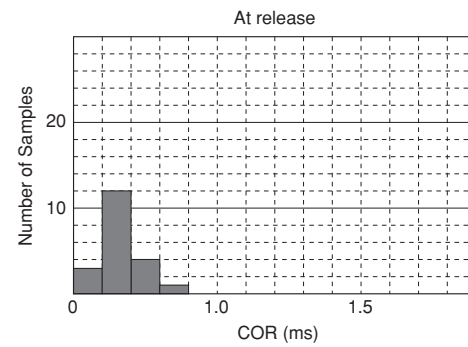
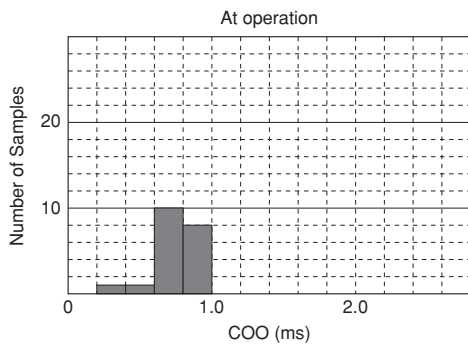

● All specifications in this catalog and production status of products are subject to change without notice. Prior to the purchase, please contact NEC Tokin for updated product data.
 ● Please request for a specification sheet for detailed product data prior to the purchase.
 ● Before using the product in this catalog, please read "Precautions" and other safety precautions listed in the printed version catalog.

4.5 Contact resistance

This section gives data on the resistance of the contacts when the contacts are closed. The number of sample used for measurement of the contact resistance is 50 each.

Figure 4.5 Contact Resistance

12 V type (MR82-12USR)

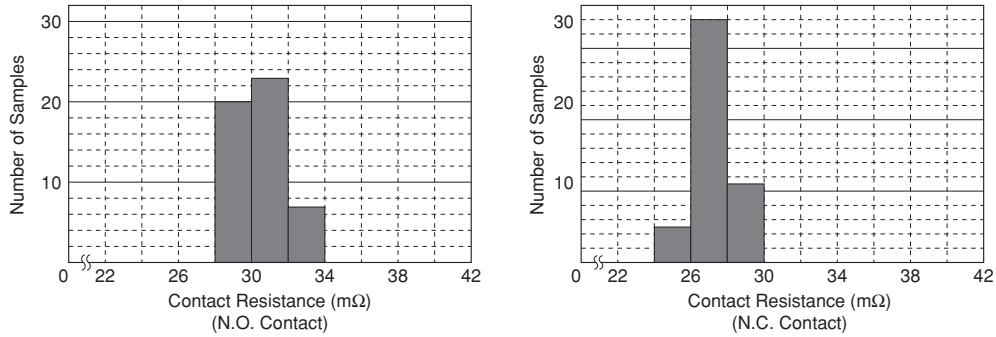

4.6 Breakdown voltage

This section gives data on the breakdown voltage between terminals of the MR82 series relay.
(Sample: MR82-12USR relay 25 pcs.)

Figure 4.6 Breakdown Voltage

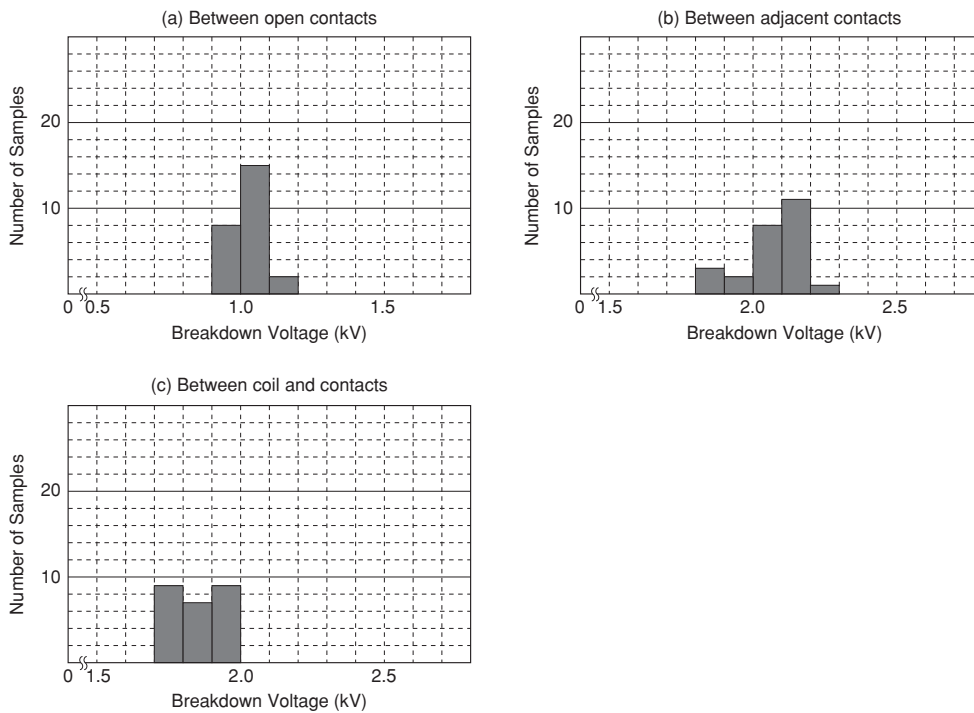

- All specifications in this catalog and production status of products are subject to change without notice. Prior to the purchase, please contact NEC Tokin for updated product data.
- Please request for a specification sheet for detailed product data prior to the purchase.
- Before using the product in this catalog, please read "Precautions" and other safety precautions listed in the printed version catalog.

5. Test Data

This chapter shows examples of the results of environmental tests (refer to 5.1 for details) and contact life tests (refer to 5.2).

The table below lists the types of tests, conditions, and data.

As the sample, the MR82-5USR and MR82-12USR are used.

Table 5 Types of Tests, Conditions, and Data

	Test	Test Conditions	Refer to Page:
Environmental test	High-temperature test	Ambient temperature: 100 °C ± 5 °C Duration: 500 hours	20
	Low-temperature test	Ambient temperature: -40 °C ± 5 °C Duration: 500 hours	21
	Moisture resistance test	Ambient temperature: 40 °C ± 5 °C Humidity: 90 to 95% RH, Duration: 240 hours	22
	Heat shock test	Ambient temperature: -55 °C/+85 °C Duration: 30 minutes/30 minutes Test cycles: 5	23
	Vibration test	Amplitude: 1.52 mm, Test time: 2 hours each in X, Y and Z directions Frequency: 10 Hz to 55 Hz, Peak acceleration: 10 G	24
	Shock test	Waveform: Half sine wave, 30 G max. 6 Times each in X, Y, and Z directions, totaling 36 times	25
Contact life test	Non-load test	25 °C	26
	Resistive load test A	10 VDC, 10 mA, 85 °C	27
	Resistive load test B	50 VDC, 100 mA, 85 °C	28



- All specifications in this catalog and production status of products are subject to change without notice. Prior to the purchase, please contact NEC Tokin for updated product data.
- Please request for a specification sheet for detailed product data prior to the purchase.
- Before using the product in this catalog, please read "Precautions" and other safety precautions listed in the printed version catalog.

5.1 Environmental tests

This section shows the results of environmental tests to be conducted to evaluate the performance of the relay under specific storage and operating environmental conditions. No abnormality was found after all the tests had been conducted.

- The operate and release voltages, contact resistance, operate and release times, and transfer time of the sample before and after each test were compared, but no major change in these parameters was observed, and the sample still satisfied the initial standard values of the parameters after the test. For details, refer to the graph for each test.
- The initial standard value of the insulation resistance of $10^9 \Omega$ or higher was still satisfied after the test.
- The initial standard value of the breakdown voltage of 500 V.AC (between open contacts) or 1000 V.AC (between coil and contact or between adjacent contacts) was satisfied for 1 minute after the test.
- After each test, no abnormality was found in the appearance. The cover of the relay was removed and the internal mechanism was also inspected visually for dirt, deformation, and other abnormalities, but no such abnormality was found.
- After each test, a sealability test was conducted to examine the sealability of the relay by immersing the relay into a fluorocarbon solution and checking to see if the internal gas of the relay leaked out. No abnormality was observed as a result of this sealability test.

5.1.1 High-temperature test (test conditions: temperature: $100 \pm 5 \text{ }^\circ\text{C}$, duration: 500 hours, sample: 5 V type, 5 pcs. each)

This test was conducted to check whether the performance of the relay is degraded after the relay has been left at the upper-limit value of the rated ambient temperature for the specified duration.

Figure 5.1 High-temperature Test

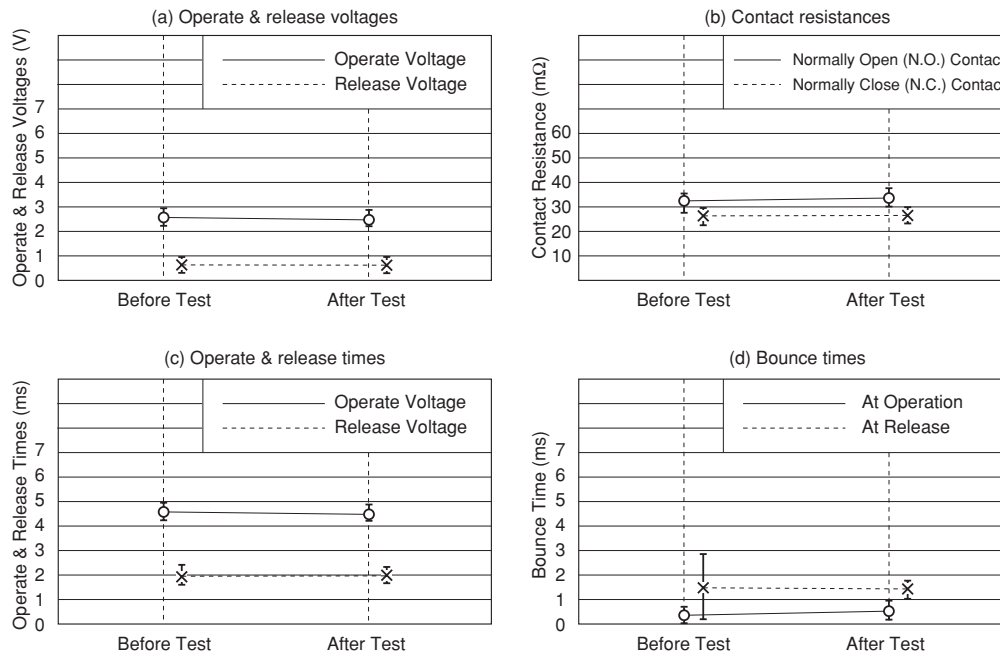

5.1.2 Low-temperature test (test conditions: temperature: $-40\text{ }^{\circ}\text{C} \pm 5\text{ }^{\circ}\text{C}$, duration: 500 hours, sample: 12 V type, 25 pcs. each)

This test is conducted to check whether the performance of the relay is degraded after the relay has been left at the lower-limit value of the rated ambient temperature for the specified duration.

Figure 5.2 Low-temperature Test

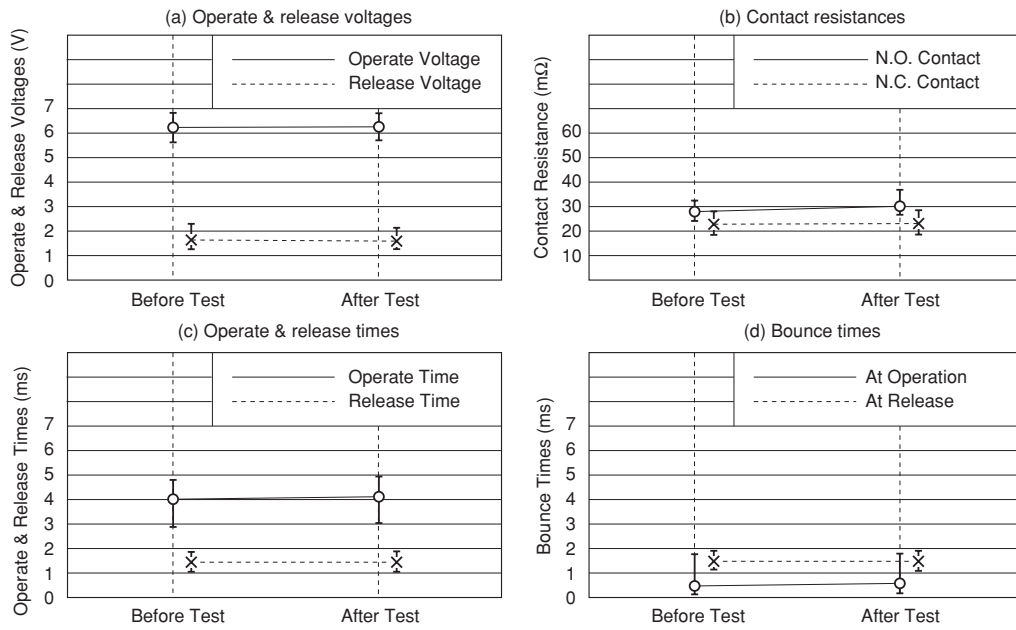

- All specifications in this catalog and production status of products are subject to change without notice. Prior to the purchase, please contact NEC Tokin for updated product data.
- Please request for a specification sheet for detailed product data prior to the purchase.
- Before using the product in this catalog, please read "Precautions" and other safety precautions listed in the printed version catalog.

5.1.3 Moisture resistance test (test conditions: temperature: $40\text{ }^{\circ}\text{C} \pm 5\text{ }^{\circ}\text{C}$, humidity: 90 to 95 % RH, duration: 240 hours, sample: 12 V type, 25 pcs. each)

This test is conducted to check whether the performance of the relay is degraded after the relay has been left in a highly humid atmosphere for the specified duration.

Figure 5.3 Moisture Resistance Test

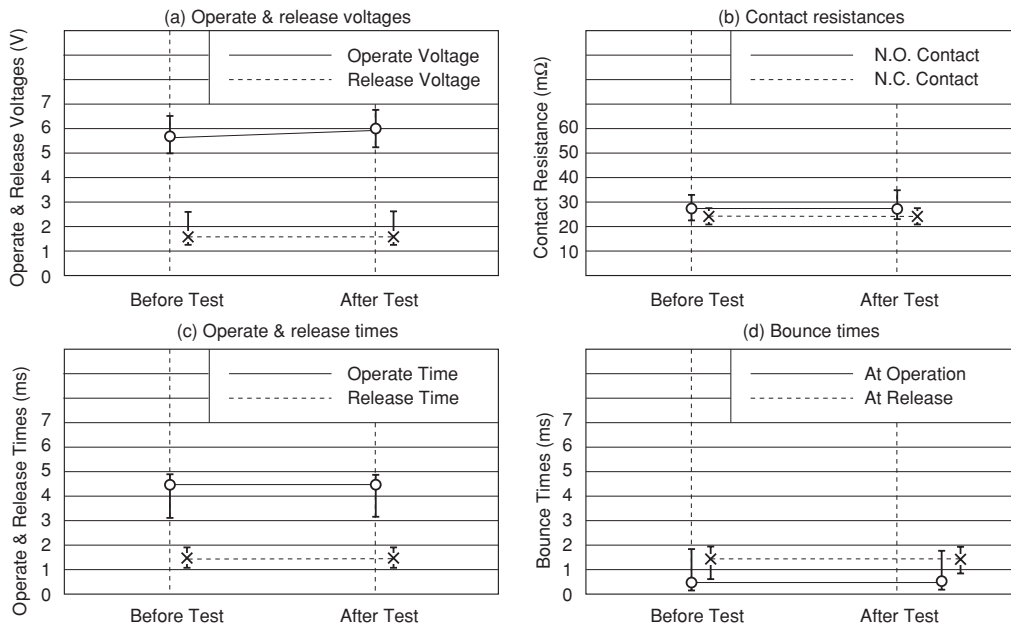

- All specifications in this catalog and production status of products are subject to change without notice. Prior to the purchase, please contact NEC Tokin for updated product data.
- Please request for a specification sheet for detailed product data prior to the purchase.
- Before using the product in this catalog, please read "Precautions" and other safety precautions listed in the printed version catalog.

5.1.4 Heat shock test (test conditions: temperature: $-55\text{ }^{\circ}\text{C}$ to $85\text{ }^{\circ}\text{C}$, duration: 30 minutes/30 minutes, test cycles: 5, sample: 5 V type, 5 pcs. each)

This test is to check whether the performance of the relay is degraded if the ambient temperature abruptly changes.

Figure 5.4 Heat Shock Test

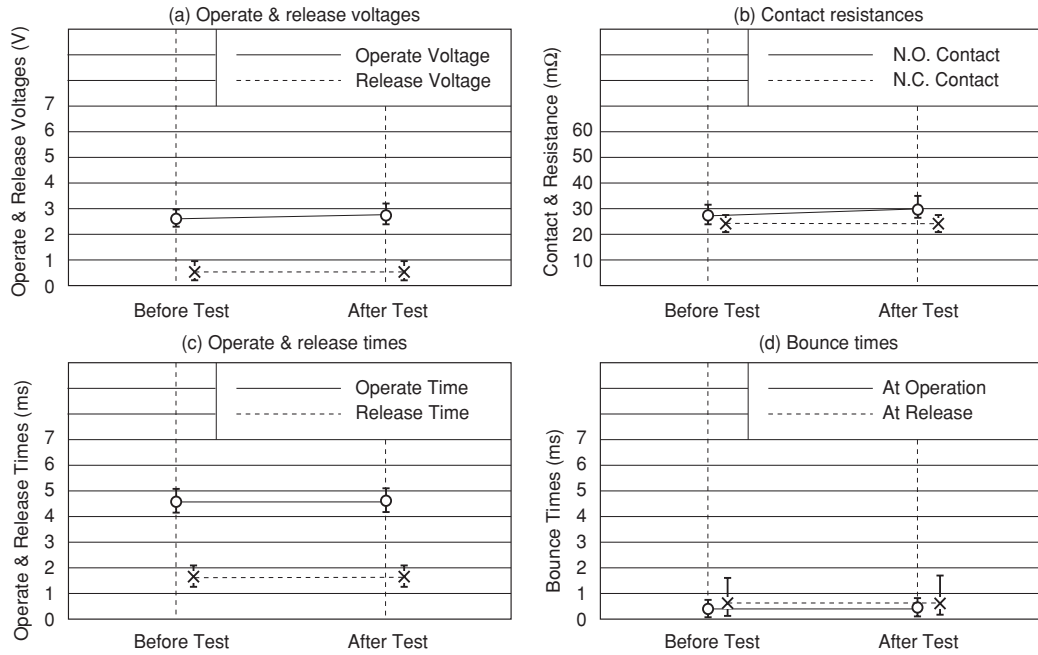

- All specifications in this catalog and production status of products are subject to change without notice. Prior to the purchase, please contact NEC Tokin for updated product data.
- Please request for a specification sheet for detailed product data prior to the purchase.
- Before using the product in this catalog, please read "Precautions" and other safety precautions listed in the printed version catalog.

5.1.5 Vibration test (test conditions: amplitude: 1.52 mm, frequency: 10 Hz to 55 Hz, 10 G peak, test time: 2 hours each in X,Y, and Z directions, totaling 6 hours, sample: 5 V type, 5 pcs. each)

This test is conducted to check whether the performance of the relay is degraded after vibration is continuously applied to the relay while the relay is being transported.

Figure 5.5 Vibration Test

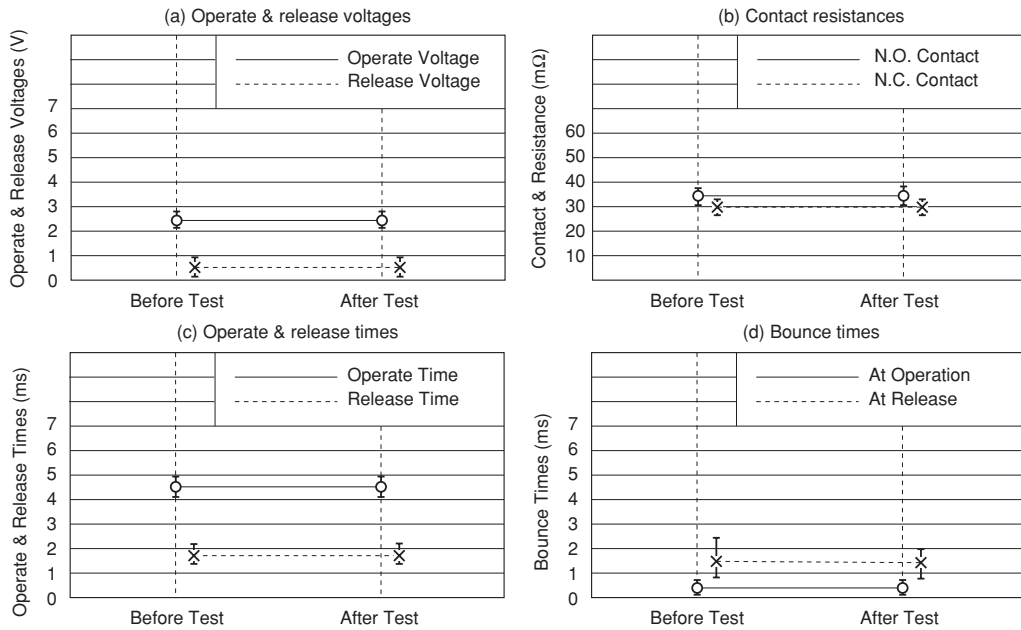

- All specifications in this catalog and production status of products are subject to change without notice. Prior to the purchase, please contact NEC Tokin for updated product data.
- Please request for a specification sheet for detailed product data prior to the purchase.
- Before using the product in this catalog, please read "Precautions" and other safety precautions listed in the printed version catalog.

5.1.6 Shock test (test conditions: waveform: half sine wave, peak acceleration: 30 G, test time: 6 times each in X, Y, and Z directions, totaling 36 times, sample: 5 V type, 5 pcs. each)

This test is conducted to check whether the performance of the relay is degraded after an abrupt shock is applied to the relay while the relay is being transported.

Figure 5.6 Shock Test

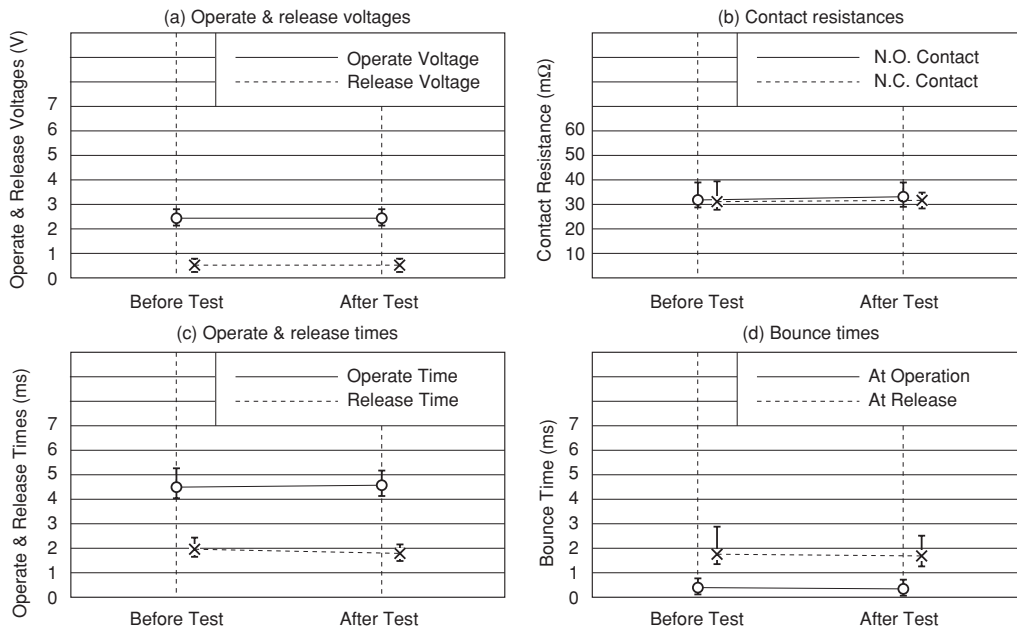

- All specifications in this catalog and production status of products are subject to change without notice. Prior to the purchase, please contact NEC Tokin for updated product data.
- Please request for a specification sheet for detailed product data prior to the purchase.
- Before using the product in this catalog, please read "Precautions" and other safety precautions listed in the printed version catalog.

5.2 Contact life tests

This section shows the results of tests conducted to examine the service life of the contacts, which has a significant influence on the life of the relay.

To test the service life of the contacts, the operate and release voltages, contact resistance, operate and release times, and bounce time of each relay is measured each time the relay has performed the specified number of operations under the specified conditions.

For changes in the characteristics, refer to the graphs shown below.

5.2.1 Non-load test (driving frequency: 10 Hz, ambient temperature: +20 °C, sample: 5 V type, 10 pcs. each)

The cleanness of the contact surfaces influences the result of this test because no electric load is applied to the relay.

Figure 5.7 Non-load Test

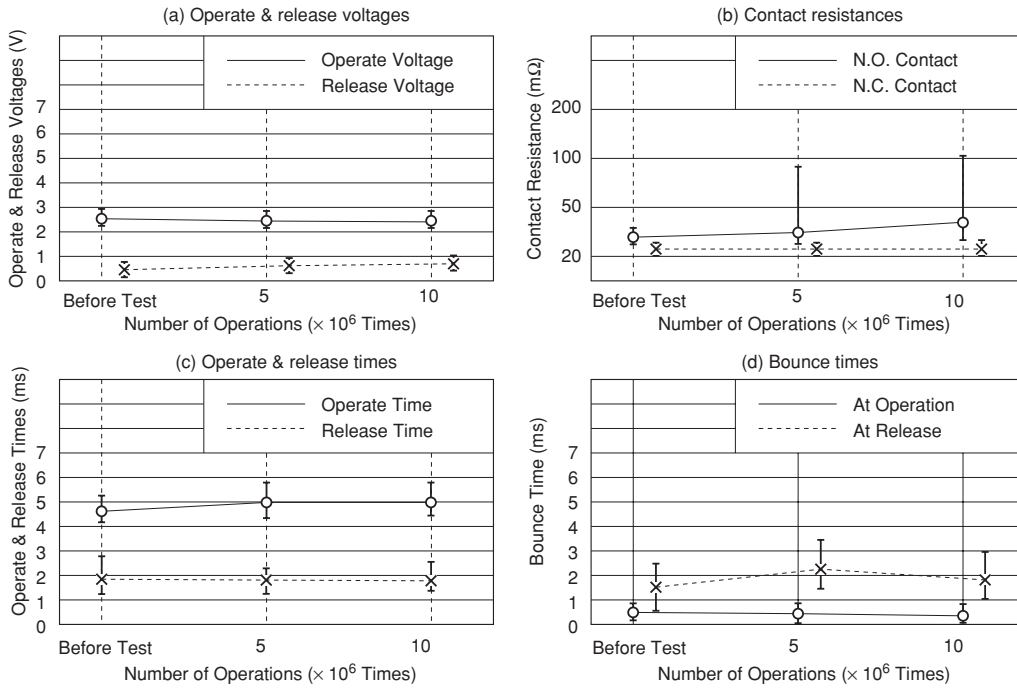

- All specifications in this catalog and production status of products are subject to change without notice. Prior to the purchase, please contact NEC Tokin for updated product data.
- Please request for a specification sheet for detailed product data prior to the purchase.
- Before using the product in this catalog, please read "Precautions" and other safety precautions listed in the printed version catalog.

5.2.2 Resistive load test A (contact load: 10 VDC, 10 mA, resistive load, driving frequency: 2 Hz, ambient temperature: +85 °C, sample: 12 V type, 50 pcs. each)

This test is conducted with a load equivalent to the signal level of an IC applied to the relay.

Figure 5.8 Resistive Load Test A

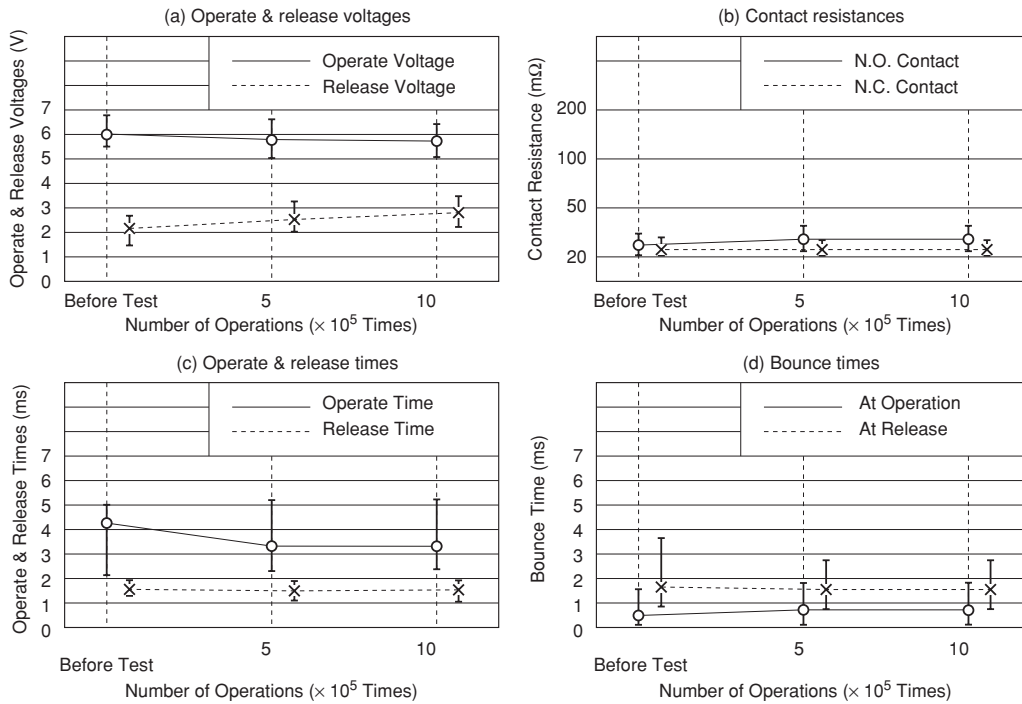

- All specifications in this catalog and production status of products are subject to change without notice. Prior to the purchase, please contact NEC Tokin for updated product data.
- Please request for a specification sheet for detailed product data prior to the purchase.
- Before using the product in this catalog, please read "Precautions" and other safety precautions listed in the printed version catalog.

5.2.3 Resistive load test B (contact load: 50 VDC, 0.1 A, resistive load, driving frequency: 5 Hz, ambient temperature: +85 °C, sample: 5 V type, 10 pcs. each)

This test was conducted with a load of medium level applied to the relay contacts.

Figure 5.9 Resistive Load Test B

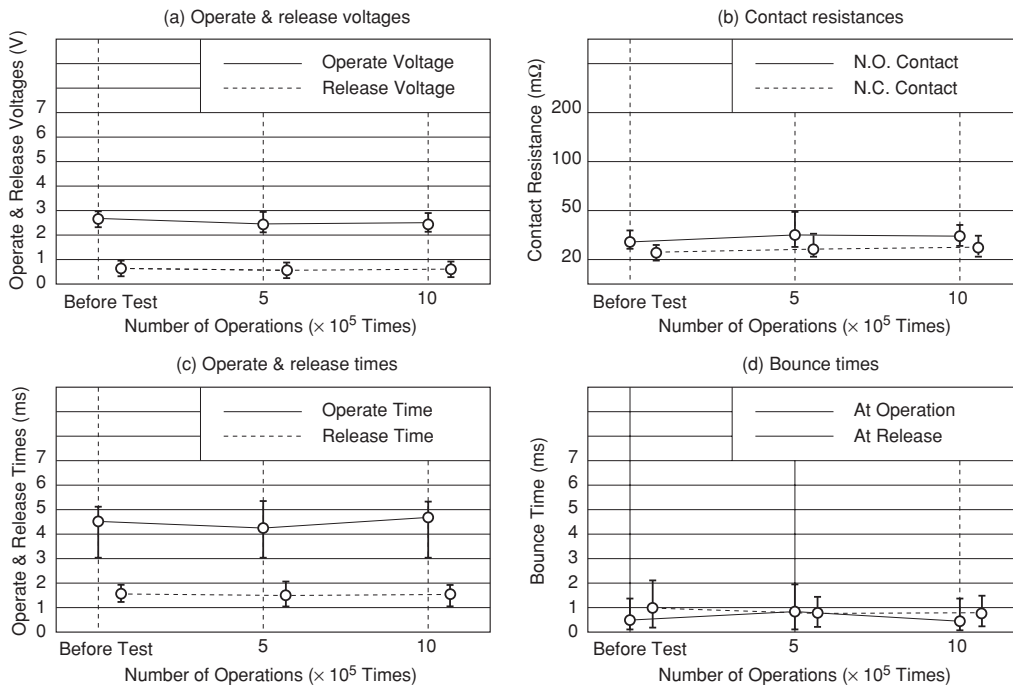

- All specifications in this catalog and production status of products are subject to change without notice. Prior to the purchase, please contact NEC Tokin for updated product data.
- Please request for a specification sheet for detailed product data prior to the purchase.
- Before using the product in this catalog, please read "Precautions" and other safety precautions listed in the printed version catalog.