

Information

**NEC/TOKIN**

# MINIATURE SIGNAL RELAYS

UC2 SERIES (DIP Type)

UD2 SERIES (SMD Type)

TECHNICAL DATA

---

© NEC/TOKIN Corporation 2006



- All specifications in this catalog and production status of products are subject to change without notice. Prior to the purchase, please contact NEC Tokin for updated product data.
- Please request for a specification sheet for detailed product data prior to the purchase.
- Before using the product in this catalog, please read "Precautions" and other safety precautions listed in the printed version catalog.



- All specifications in this catalog and production status of products are subject to change without notice. Prior to the purchase, please contact NEC Tokin for updated product data.
- Please request for a specification sheet for detailed product data prior to the purchase.
- Before using the product in this catalog, please read "Precautions" and other safety precautions listed in the printed version catalog.

# CONTENTS

<b>1. PREFACE</b> .....	<b>4</b>
<b>2. STRUCTURE</b> .....	<b>5</b>
<b>3. BASIC CHARACTERISTICS</b> .....	<b>6</b>
3.1 Switching Power .....	6
3.2 Maximum Coil Voltage .....	6
3.3 Coil Temperature Rise .....	7
3.4 Driving Power vs. Timing .....	8
3.5 Thermal Characteristics .....	9
3.6 Magnetic Interference .....	10
3.7 High-Frequency Characteristics .....	11
3.8 Resistance to Surge Voltage .....	12
3.9 Current-Carrying Capacity .....	13
<b>4. DISTRIBUTION OF CHARACTERISTICS</b> .....	<b>14</b>
4.1 Operate & Release Voltages (set & reset voltages) .....	14
4.2 Operate & Release Time (set & reset times) .....	15
4.3 Transfer Time .....	16
4.4 Bounce Time .....	17
4.5 Contact Resistance .....	18
4.6 Breakdown Voltage .....	18
<b>5. TEST DATA</b> .....	<b>19</b>
5.1 Environmental Tests .....	20
5.1.1 High-temperature test .....	20
5.1.2 Low-temperature test .....	21
5.1.3 Moisture resistance test .....	22
5.1.4 Heat shock test .....	23
5.1.5 Vibration test .....	24
5.1.6 Shock test (destructive failure) .....	25
5.1.7 Shock test (misoperation) .....	26
5.1.8 Resistance to flow solder heat test .....	27
5.1.9 Resistance to reflow solder heat test .....	28
5.2 Contact Life Tests .....	30
5.2.1 Non-load test (Mechanical life test, $T_a = 25^\circ\text{C}$ ) .....	30
5.2.2 Resistive load test A (50 Vdc, 0.1A, $T_a = 25^\circ\text{C}$ ) .....	31
5.2.3 Resistive load test B (30 Vdc, 1A, $T_a = 25^\circ\text{C}$ ) .....	32
5.2.4 Resistive load test C (125 Vac, 0.3A, $T_a = 25^\circ\text{C}$ ) .....	33



- All specifications in this catalog and production status of products are subject to change without notice. Prior to the purchase, please contact NEC Tokin for updated product data.
- Please request for a specification sheet for detailed product data prior to the purchase.
- Before using the product in this catalog, please read "Precautions" and other safety precautions listed in the printed version catalog.

## 1. PREFACE

Miniature signal relays are used in a wide range of application fields including communication, measurement, and factory automation. This document gives the basic characteristics and test data of NEC's UC2 and UD2 series miniature signal relays.

- Notes**
1. The symbol  $\top$  shown in the graphs throughout this document indicates the maximum value of the data. Likewise,  $\perp$  indicates the minimum value, and  $\downarrow(*)$  indicates the mean value.
  2. When a relay is driven by an IC, a protective element such as a diode may be connected in parallel with the relay coil to protect the IC from damage caused by the counter-electromotive force (EMF) due to the inductance of the coil. However, unless otherwise specified, the operate time and release time (set and reset times) shown in this document are measured without such a protective element.

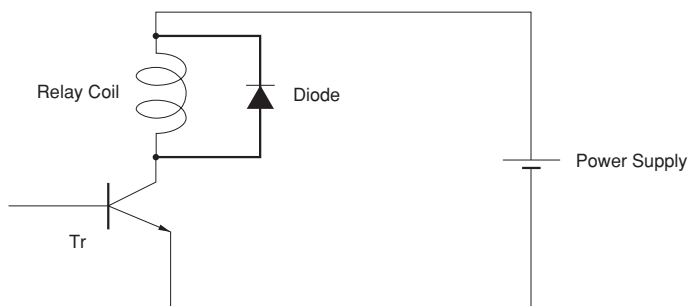

### For Right Use of Miniature Relays

#### **DO NOT EXCEED MAXIMUM RATINGS.**

Do not use relays under exceeding conditions such as over ambient temperature, over voltage and over current. Incorrect use could result in abnormal heating, damage to related parts or cause burning.

#### **READ CAUTIONS IN THE SELECTION GUIDE.**

Read the cautions described in NEC/TOKIN's "Miniature Relays" (0123EMDD03VOL01E) when you choose relays for your application.



- All specifications in this catalog and production status of products are subject to change without notice. Prior to the purchase, please contact NEC Tokin for updated product data.
- Please request for a specification sheet for detailed product data prior to the purchase.
- Before using the product in this catalog, please read "Precautions" and other safety precautions listed in the printed version catalog.

## 2. STRUCTURE

Figure 2.1 shows the structures of the UC2 and the UD2 series relays. UC2 series relay has a terminal configuration called dual in-line leads (DIL), and UD2 series relay has a resistibility to solder heat, and a terminal configuration that conforms to surface mounting. Table 2.1 lists the parts constituting relay.

UC2 series and UD2 series relays have a common structure except difference of a terminal configuration and some parts.

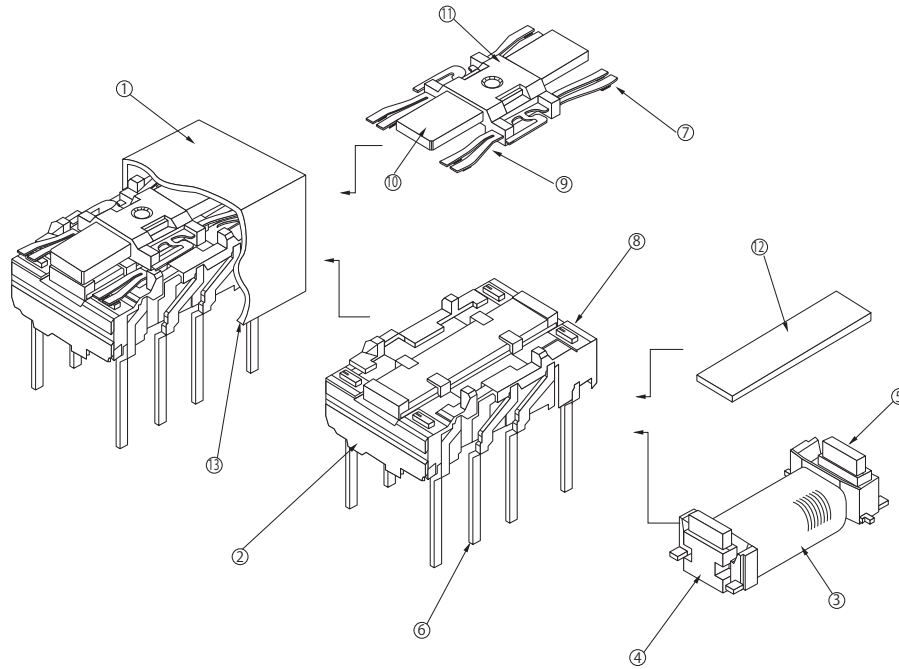

**Figure 2.1 Structure of the UC2/UD2 Series Relay**

**Table 2.1 Parts of UC2/UD2 Series Relay**

No.	Parts	Material
		UC2/UD2 Series
1	Cover	Liquid crystalline polymer #
2	Base	Liquid crystalline polymer #
3	Coil wire	Polyurethane copper wire
4	Coil spool	Liquid crystalline polymer #
5	Core	Pure iron
6	Terminal	Phosphor bronze (surface is treated with preparatory solder)
7	Moving contact	Au-alloy + Ag-alloy
8	Stationary contact	Au-alloy + Ag-alloy
9	Contact spring	Phosphor bronze
10	Armature	Pure iron
11	Armature block mold	Liquid crystalline polymer #
12	Magnet	Fe-Cr-Co magnet
13	Sealing material	Epoxy resin

**Note:** RoHS Compliant

#: Conforms to UL94V-0



- All specifications in this catalog and production status of products are subject to change without notice. Prior to the purchase, please contact NEC Tokin for updated product data.
- Please request for a specification sheet for detailed product data prior to the purchase.
- Before using the product in this catalog, please read "Precautions" and other safety precautions listed in the printed version catalog.

### 3. BASIC CHARACTERISTICS

This section provides data necessary for designing an external circuit that uses the relay.

UC2 and UD2 series relays are designed with common specifications. So, this section shows common characteristics of UC2 and UD2 series.

#### 3.1 Switching Power

If the contact load voltage and current of the relay are in the region enclosed by the solid and dotted lines in the figure below, the relay can perform stable switching operation. If the relay is used at a voltage or current exceeding this region, the life of the contacts may be significantly shortened.

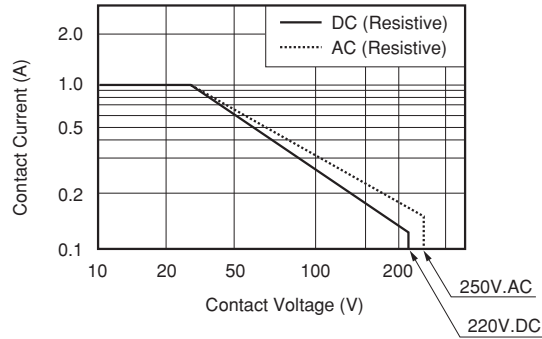

Figure 3.1 Switching Power

#### 3.2 Maximum Coil Voltage

Figure 3.2 shows the ratio of maximum voltage that can be continuously applied to the coil of the relay to the nominal voltage. As long as the relay is used in the enclosed region in this figure, the coil is not damaged due to burning and the coil temperature does not rise to an abnormally high level.

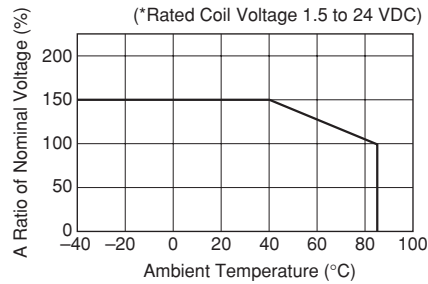

Figure 3.2 Maximum Voltage Applied to Coil



- All specifications in this catalog and production status of products are subject to change without notice. Prior to the purchase, please contact NEC Tokin for updated product data.
- Please request for a specification sheet for detailed product data prior to the purchase.
- Before using the product in this catalog, please read "Precautions" and other safety precautions listed in the printed version catalog.

### 3.3 Coil Temperature Rise

Figure 3.3 shows the relation between the rise in coil temperature and the power (product of the coil voltage and current) dissipated by the coil. This figure shows the difference between the temperature before the power is applied to the coil and the saturated temperature after application of power to the coil.

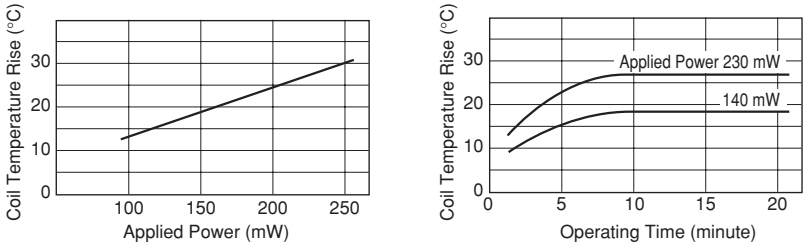

Figure 3.3 Coil Temperature Rise



- All specifications in this catalog and production status of products are subject to change without notice. Prior to the purchase, please contact NEC Tokin for updated product data.
- Please request for a specification sheet for detailed product data prior to the purchase.
- Before using the product in this catalog, please read "Precautions" and other safety precautions listed in the printed version catalog.

### 3.4 Driving Power vs. Timing

Figure 3.4 (1) shows the relations among the power applied to drive the relay, the operate time, and the bounce time. Figure 3.4 (2) shows the relations among the supplied power, the release time, and the bounce time, and Figure 3.4 (3) shows the relations among the supplied power, the release time, and the bounce time when a diode is not connected to the coil to absorb surges.

#### (1) Operate time

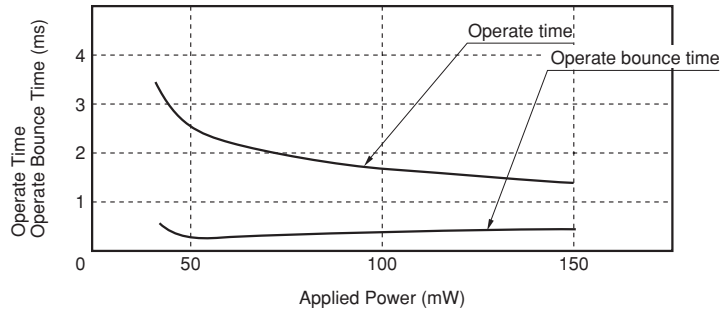

#### (2) Release time (with diode)

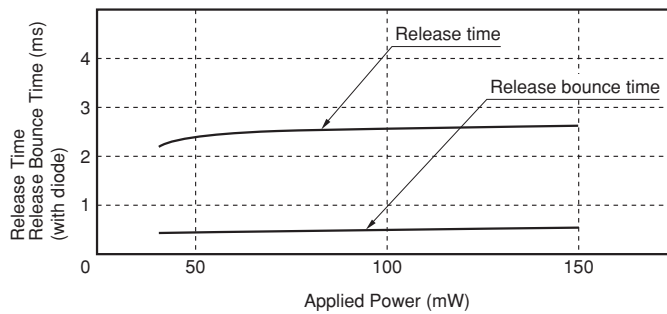

#### (3) Release time

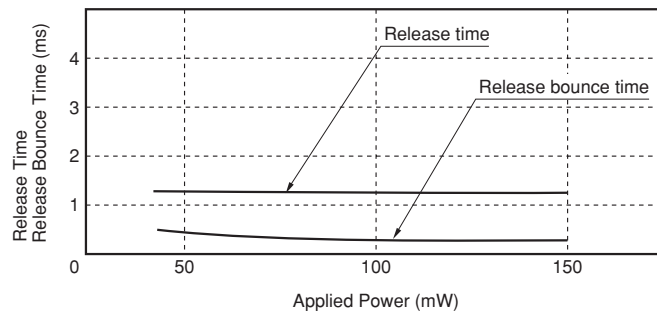

Figure 3.4 Driving Power vs. Timing



- All specifications in this catalog and production status of products are subject to change without notice. Prior to the purchase, please contact NEC Tokin for updated product data.
- Please request for a specification sheet for detailed product data prior to the purchase.
- Before using the product in this catalog, please read "Precautions" and other safety precautions listed in the printed version catalog.

### 3.5 Thermal Characteristics

The general characteristics of a relay gradually change with the ambient temperature. Figure 3.5 shows the typical characteristics of the UC2, UD2 series relay.

#### (1) Operate & release voltages

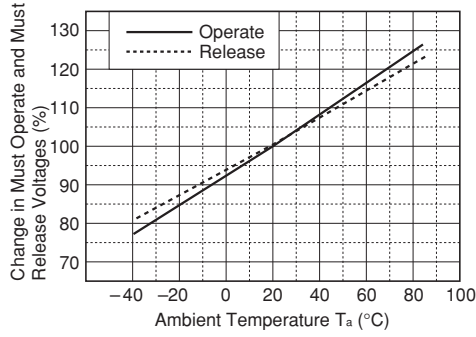

#### (2) Contact resistance\*

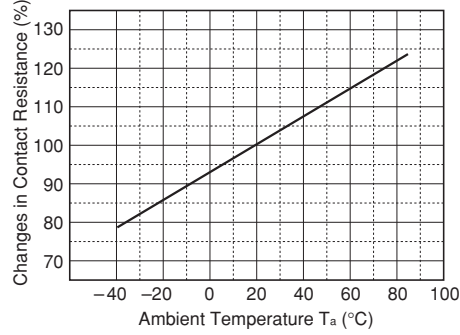

#### (4) Transfer times

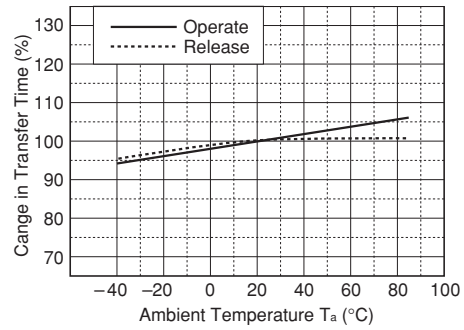

#### (3) Operate & release times

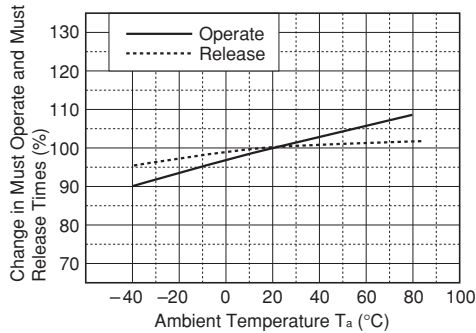

#### (5) Coil resistance

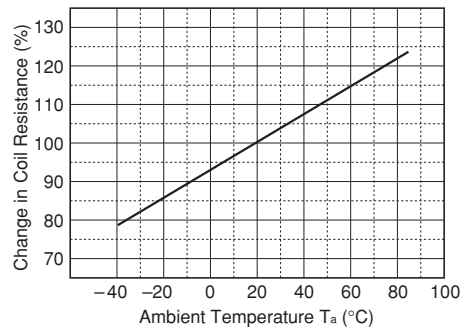

Figure 3.5 Temperature Characteristics

\* The contact resistance includes the conductive resistance of the terminals. It is this conductive resistance component that can change with the temperature.



- All specifications in this catalog and production status of products are subject to change without notice. Prior to the purchase, please contact NEC Tokin for updated product data.
- Please request for a specification sheet for detailed product data prior to the purchase.
- Before using the product in this catalog, please read "Precautions" and other safety precautions listed in the printed version catalog.

### 3.6 Magnetic Interference

This section describes changes in the operate voltage caused by mutual magnetic interference when several relays are closely mounted on a printed circuit board (PCB). Figure 3.6 (1) shows the distance among the relays mounted on the PCB. As shown, the pin pitch of each relay is 2.54 mm. Figure 3.6 (2) shows the relay that is subject to interference. In this figure, the hatched relay shown in the center of each relay arrangement is subject to interference, and the surrounding relays influence the center relay. The condition under which the center relay suffers interference and the surrounding relays affect the center relay differs depending on whether power is supplied to each relay. Figure 3.6 (3) shows the deviation in percent of the operate and release voltages of the center relays in Figure 3.6 (2).

#### (1) Relay arrangement

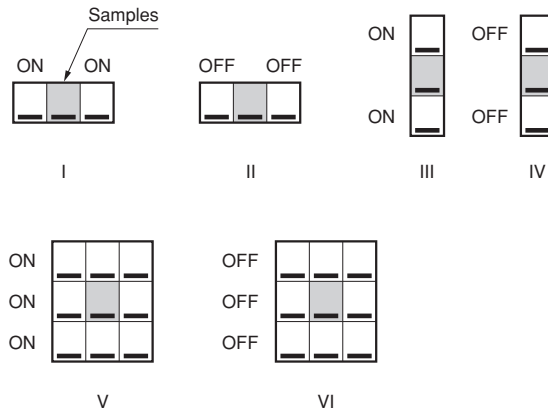

#### (2) Deviation of must operate and must release voltage

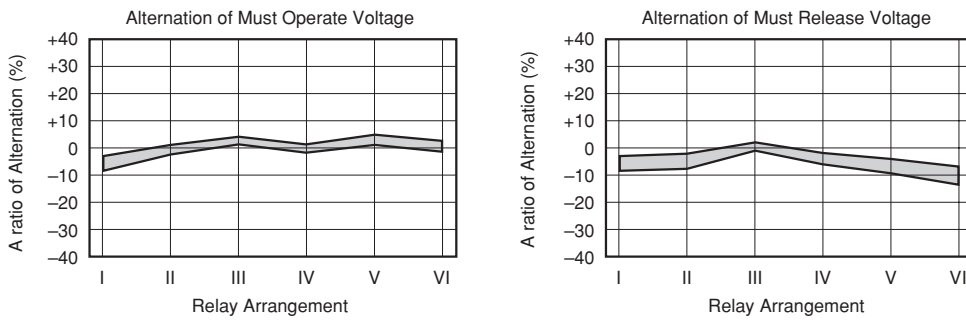

Figure 3.6 Magnetic Interference



- All specifications in this catalog and production status of products are subject to change without notice. Prior to the purchase, please contact NEC Tokin for updated product data.
- Please request for a specification sheet for detailed product data prior to the purchase.
- Before using the product in this catalog, please read "Precautions" and other safety precautions listed in the printed version catalog.

### 3.7 High-Frequency Characteristics

Figure 3.7 shows the performance of the UC2 and the UD2 series relays when a high-frequency signal is switched by the contacts of the relay. Figure 3.7 (1) shows the test circuit. Figure 3.7 (2) shows the isolation loss of the relay. Figure 3.7 (3) and Figure 3.7 (4) respectively show the insertion loss and return loss.

#### (1) Test circuit

Test equipment: HP8753B Network Analyzer (characteristic impedance: 50 Ω)

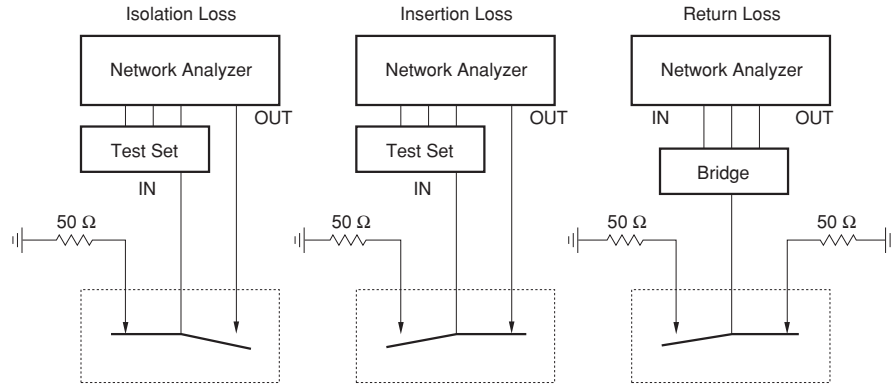

#### (2) Isolation loss

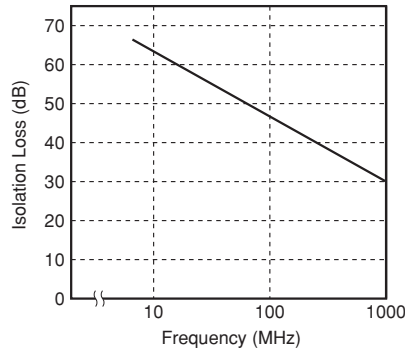

#### (3) Insertion loss

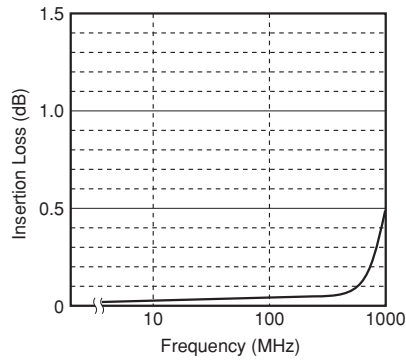

#### (4) Return loss

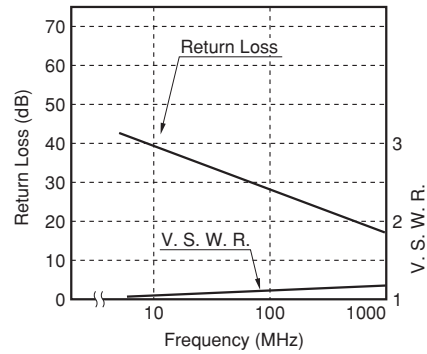

Figure 3.7 High-frequency characteristics



- All specifications in this catalog and production status of products are subject to change without notice. Prior to the purchase, please contact NEC Tokin for updated product data.
- Please request for a specification sheet for detailed product data prior to the purchase.
- Before using the product in this catalog, please read "Precautions" and other safety precautions listed in the printed version catalog.

### 3.8 Resistance to Surge Voltage

When a relay is used in a communication circuit, it may be subjected to a lightning surge via the circuit or due to induction. A surge voltage test is conducted to measure the resistance of the UC2 and the UD2 series relays to surge voltage.

#### (1) Test condition 1

The voltage waveform used for this test is specified by the Federal Communications Commission (FCC) Standard Part 68.

The UC2 series relay can withstand even if the surge voltage shown in Figure 3.8 is applied (1) between opening contacts, (2) between coil and contacts, or (3) between adjacent contacts.

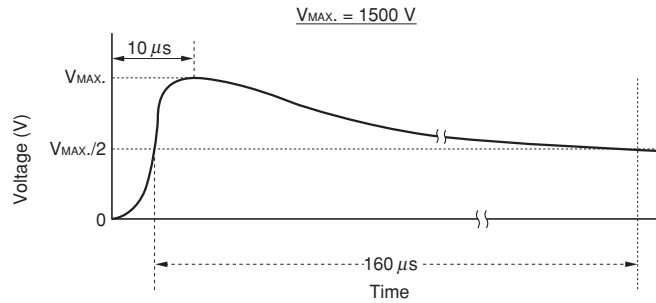

Figure 3.8 Surge Voltage Waveform

#### (2) Test condition 2

The voltage waveform used for this test is specified by the Bellcore Standard. The UC2 and the UD2 series relay can withstand even if the surge voltage shown in Figure 3.9 is applied between coil and contact.

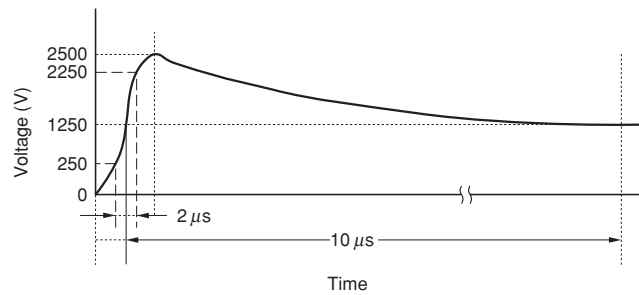

Figure 3.9 Surge Current Waveform



- All specifications in this catalog and production status of products are subject to change without notice. Prior to the purchase, please contact NEC Tokin for updated product data.
- Please request for a specification sheet for detailed product data prior to the purchase.
- Before using the product in this catalog, please read "Precautions" and other safety precautions listed in the printed version catalog.

### 3.9 Current-Carrying Capacity

Check that the relay does not show abnormal operation by applying a current through closed contacts. This relay can carry a current of 1 A, however, a current of 1.5 A is applied in this section.

- (1) Samples: UD2-4.5NU 5 pieces
- (2) Testing conditions: 4.5 V applied to the coil  
Current of 1.5 A applied to the contacts for 30 minutes.
- (3) Test results: The variation in the characteristic value is small as shown in the figures below. Therefore, a current of 1 A can be passed through without problem.

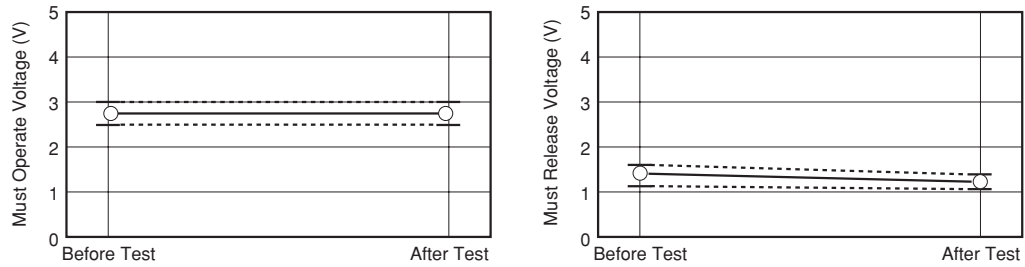

Figure 3.10 Resistance to Carrying Current



- All specifications in this catalog and production status of products are subject to change without notice. Prior to the purchase, please contact NEC Tokin for updated product data.
- Please request for a specification sheet for detailed product data prior to the purchase.
- Before using the product in this catalog, please read "Precautions" and other safety precautions listed in the printed version catalog.

#### 4. DISTRIBUTION OF CHARACTERISTICS

This chapter presents the distribution data of the general characteristic values of the UC2 and the UD2 series relays, because they are designed with common specifications. The data shown in this chapter are sampled from a certain production lot, and do not necessarily guarantee the characteristics of any particular lot that is shipped.

##### 4.1 Operate & Release Voltages (set & reset voltages)

###### (1) Non-latching, 3 V Type (UD2-3NU, 90 Pieces)

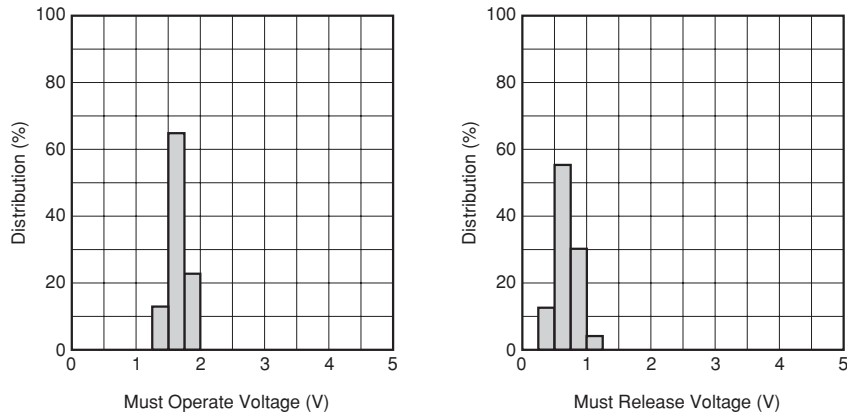

###### (2) Non-latching, 4.5 V Type (UD2-4.5NU, 40 Pieces)

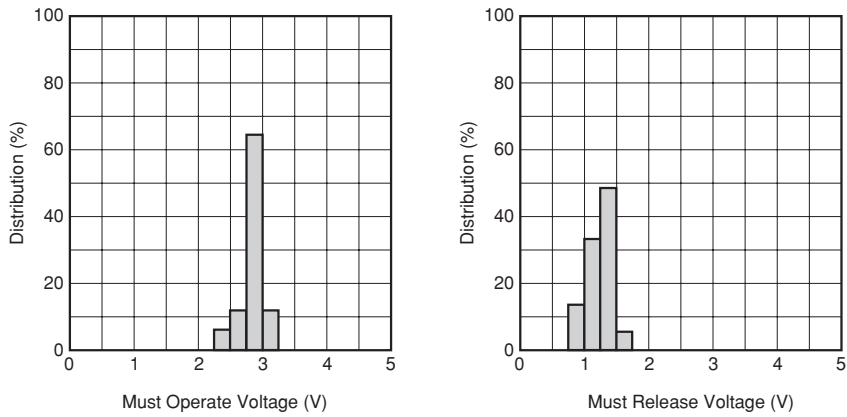

###### (3) Latching, 3 V Type (UD2-3SNU, 40 Pieces)

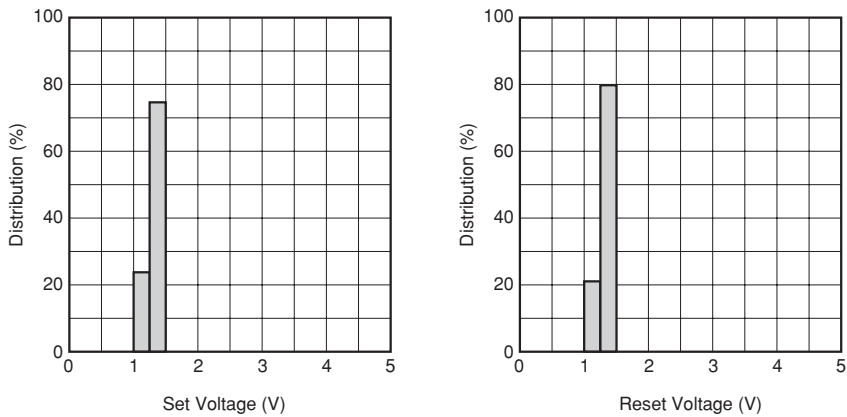

Figure 4.1 Operate & Release Voltages



- All specifications in this catalog and production status of products are subject to change without notice. Prior to the purchase, please contact NEC Tokin for updated product data.
- Please request for a specification sheet for detailed product data prior to the purchase.
- Before using the product in this catalog, please read "Precautions" and other safety precautions listed in the printed version catalog.

## 4.2 Operate & Release Times (set & reset times)

This section shows the operate time that elapses from the time when the relay coil is energized until the relay contacts close, and the release time that elapses from the time when the relay coil is deenergized until the closed contacts open.

### (1) Non-latching, 12 V Type (UD2-3NU, 90 Pieces)

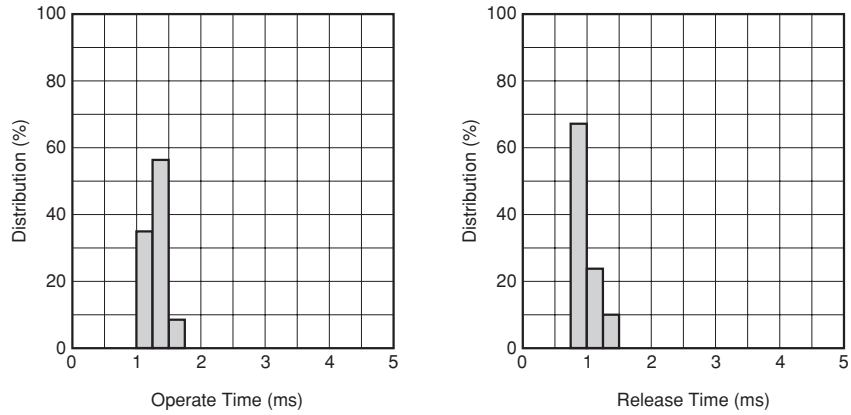

### (2) Non-latching, 4.5 V Type (UD2-4.5NU, 40 Pieces)

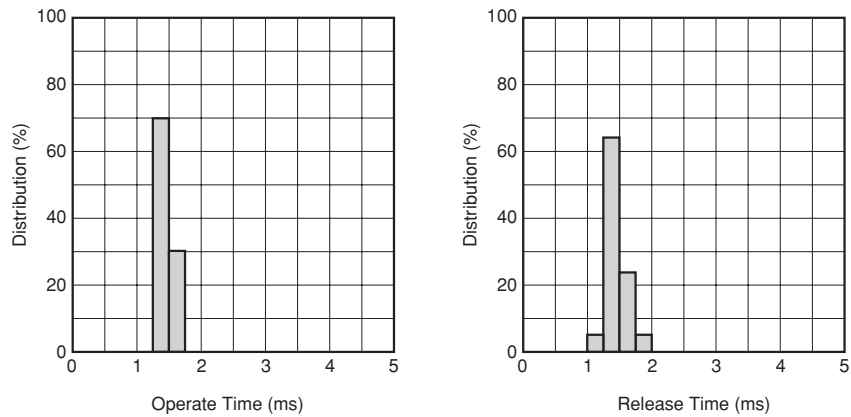

### (3) Latching, 3 V Type (UD2-3SNU, 40 Pieces)

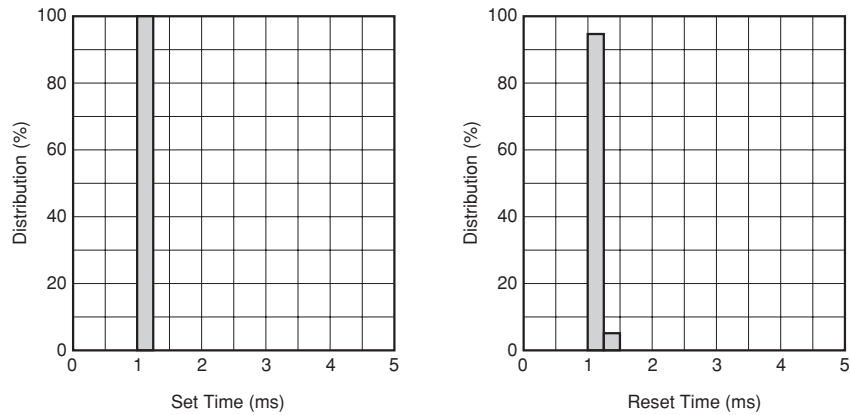

Figure 4.2 Operate & Release Times



- All specifications in this catalog and production status of products are subject to change without notice. Prior to the purchase, please contact NEC Tokin for updated product data.
- Please request for a specification sheet for detailed product data prior to the purchase.
- Before using the product in this catalog, please read "Precautions" and other safety precautions listed in the printed version catalog.

### 4.3 Transfer Time

This section gives data on the transfer time, which is the total time between the breaking of one set of contacts and the making of another.

#### (1) Non-latching, 3 V Type (UD2-3NU, 90 Pieces)

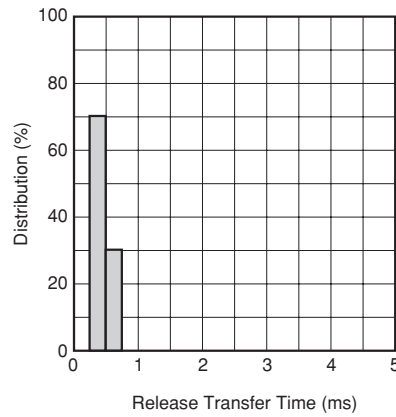
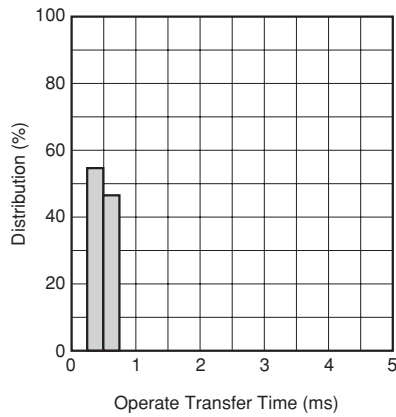

#### (2) Non-latching, 4.5 V Type (UD2-4.5NU, 40 Pieces)

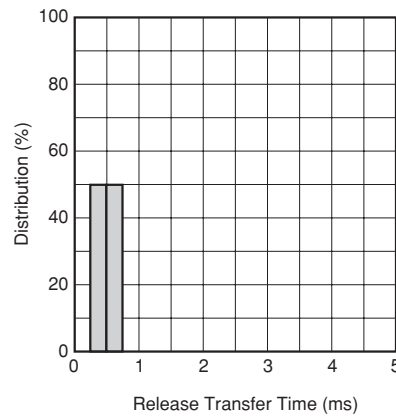
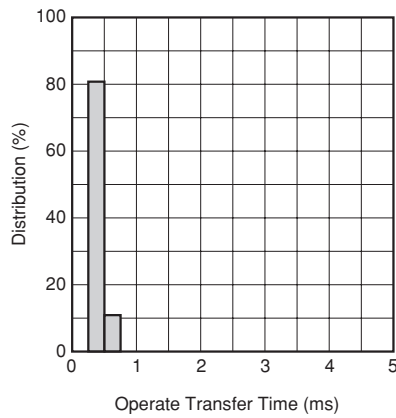

#### (3) Latching, 3 V Type (UD2-3SNU, 40 Pieces)

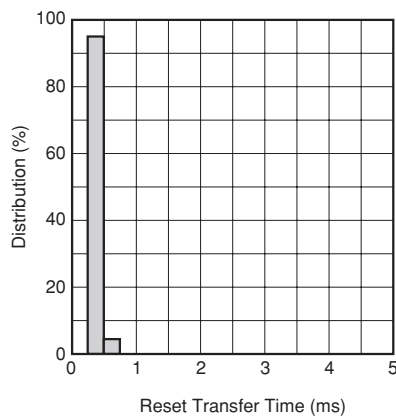
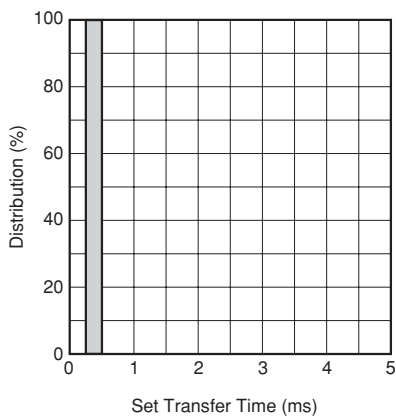

Figure 4.3 Transfer Times



- All specifications in this catalog and production status of products are subject to change without notice. Prior to the purchase, please contact NEC Tokin for updated product data.
- Please request for a specification sheet for detailed product data prior to the purchase.
- Before using the product in this catalog, please read "Precautions" and other safety precautions listed in the printed version catalog.

#### 4.4 Bounce Time

##### (1) Non-latching, 3 V Type (UD2-3NU, 90 Pieces)

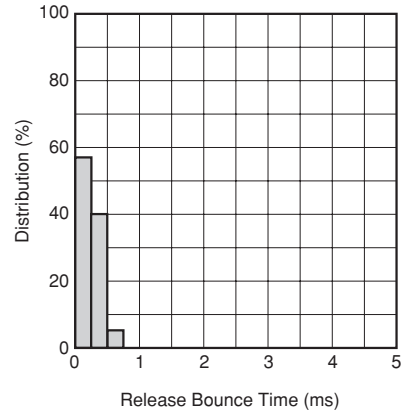
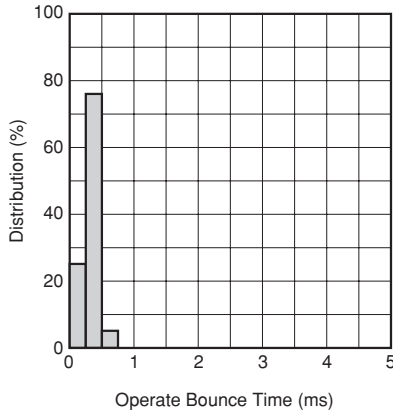

##### (2) Non-latching, 4.5 V Type (UD2-4.5NU, 40 Pieces)

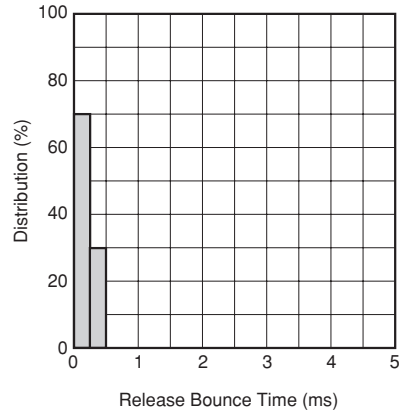
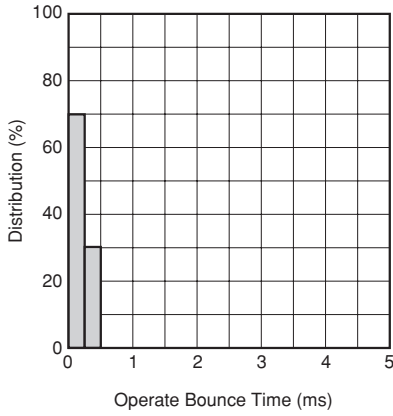

##### (3) Latching, 3 V Type (UD2-3SNU, 40 Pieces)

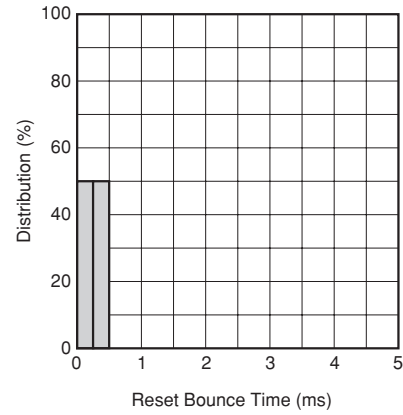
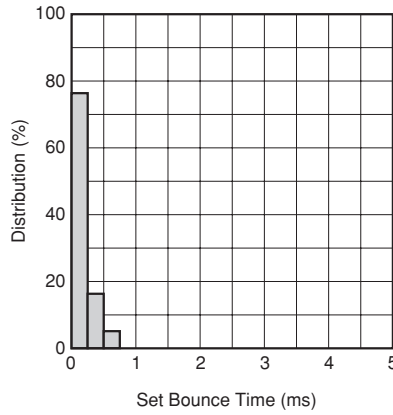

Figure 4.4B Timing



- All specifications in this catalog and production status of products are subject to change without notice. Prior to the purchase, please contact NEC Tokin for updated product data.
- Please request for a specification sheet for detailed product data prior to the purchase.
- Before using the product in this catalog, please read "Precautions" and other safety precautions listed in the printed version catalog.

#### 4.5 Contact Resistance

This section gives data on the resistance of the contacts when the contacts are closed.

##### (1) Non-latching, 3 V Type (UD2-3NU, 90 Pieces)

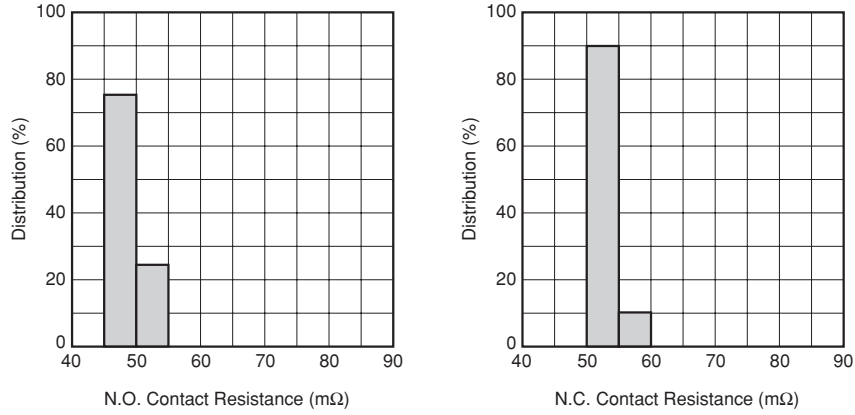

Figure 4.5 Contact Resistance

#### 4.6 Breakdown Voltage

This section gives data on the breakdown voltage between terminals of the UD2 series relay.

##### (1) Non-latching, 4.5 V Type (UD2-4.5NU, 10 Pieces)

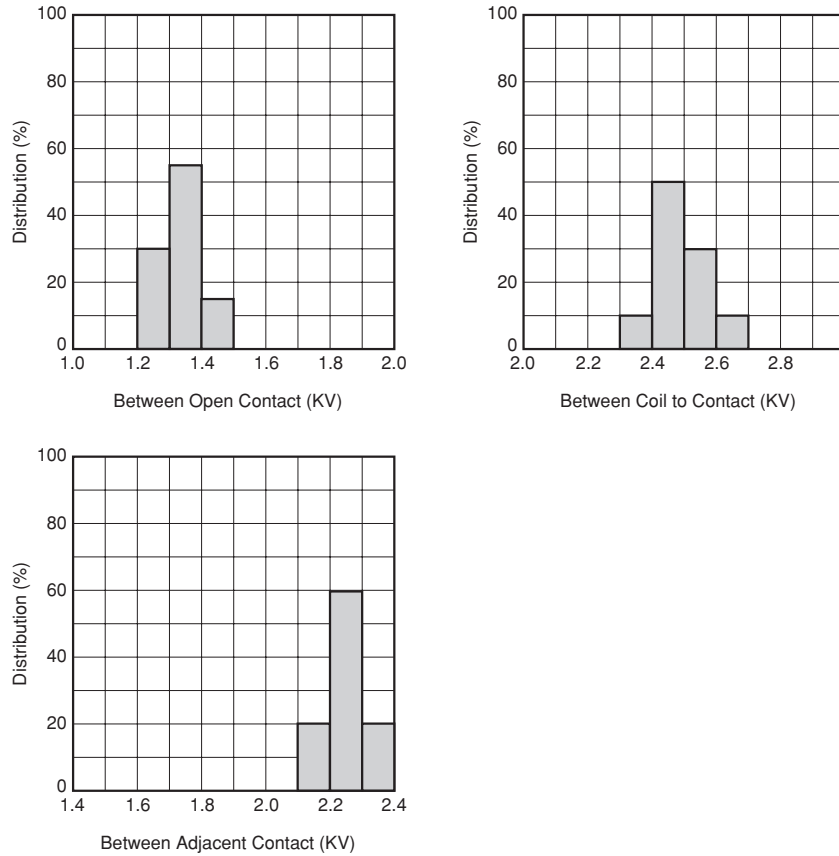

Figure 4.6 Breakdown Voltage



- All specifications in this catalog and production status of products are subject to change without notice. Prior to the purchase, please contact NEC Tokin for updated product data.
- Please request for a specification sheet for detailed product data prior to the purchase.
- Before using the product in this catalog, please read "Precautions" and other safety precautions listed in the printed version catalog.

## 5. TEST DATA

This chapter shows examples of the results of environmental tests (refer to 5.1 for details) and contact life tests (refer to 5.2). The table below lists the types of tests, conditions, and data.

**Table 5 Types of Tests, Conditions, and Data**

Test		Test Conditions	Refer to Page:
Environmental test	High-temperature test	Ambient temperature: +85°C Duration: 800 hours	20
	Low-temperature test	Ambient temperature: -40°C Duration: 500 hours	21
	Moisture resistance test	Ambient temperature: -10°C to +65°C Humidity: 90 to 95% RH, test cycles: 10	22
	Heat shock test	Ambient temperature: -40°C/+85°C (30 minutes/30 minutes) Test cycles: 100	23
	Vibration test	Double Amplitude: 3 mm, Test time: 2 hours each in X, Y, and Z directions Frequency: 10 Hz to 55 Hz	24
	Shock test (destructive failure)	Waveform: Half sine wave, 10 ms. 6 Times in X, Y, and Z directions, 9800 mm/s <sup>2</sup>	25
	Shock test (misoperation)	Wave form: Half sine ware, 0.5 ms ±X, ±Y, and ±Z directions, 9800 mm/s <sup>2</sup>	26
	Resistance to flow solder heat test	Solder temperature: 260 ± 10°C, Pre-heating 100°C/1 minute Immersion time: 10 seconds	27
	Resistance to reflow solder heat test	Maximum temperature: 240°C, Expose twice Refer to section 5.1.9	28, 29
Contact life test	Non-load test	Mechanical life test, 25°C	30
	Resistive load test A	50 V.DC, 0.1 A, 85°C	31
	Resistive load test B	30 V.DC, 1A, 25°C	32
	Resistive load test C	125 V AC, 0.3A, 25°C	33

**(Note)** Environment testing has confirmed that the specifications described below are satisfied after testing.

- Insulation resistance: 1000 MΩ/insulation terminal
- Tolerance voltage:
  - Between open contacts: 1000 VAC
  - Between adjacent contacts: 1000 VAC
  - Between coil contacts: 1500 VAC
- Air tightness (bubble leakage): Check for bubbles by soaking the relay in phlorocarbon liquid (85°C) for 60 seconds.



- All specifications in this catalog and production status of products are subject to change without notice. Prior to the purchase, please contact NEC Tokin for updated product data.
- Please request for a specification sheet for detailed product data prior to the purchase.
- Before using the product in this catalog, please read "Precautions" and other safety precautions listed in the printed version catalog.

## 5.1 Environmental Tests

### 5.1.1 High-temperature test

#### (1) Non-latching, 4.5 V Type (UC2-4.5NU, 10 Pieces)

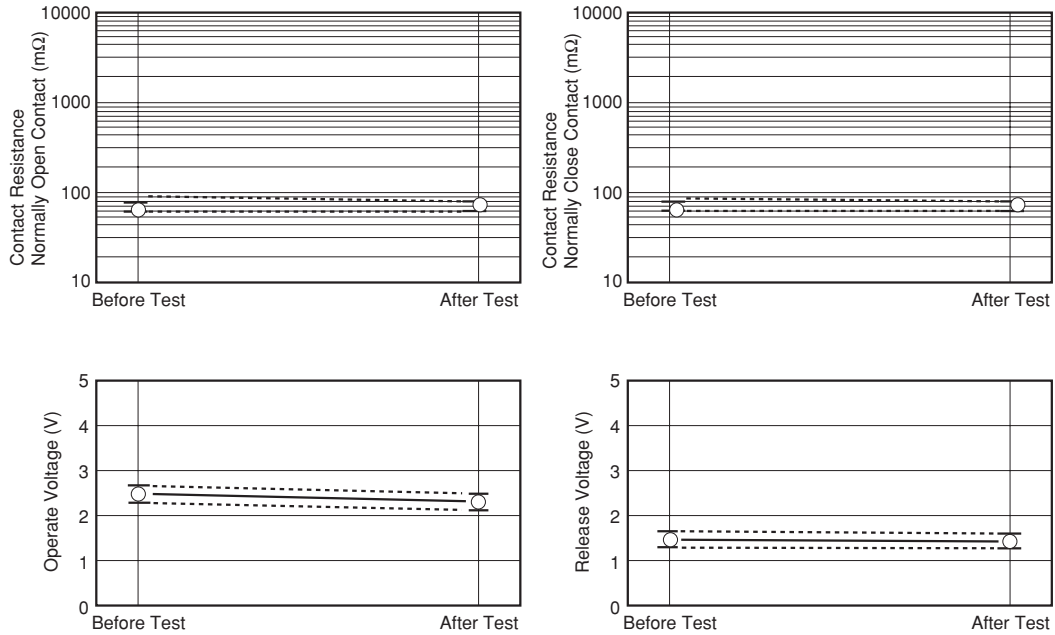

Figure 5.1 (1) High-temperature Test

#### (2) Non-latching, 4.5 V Type (UD2-4.5NU, 10 Pieces)

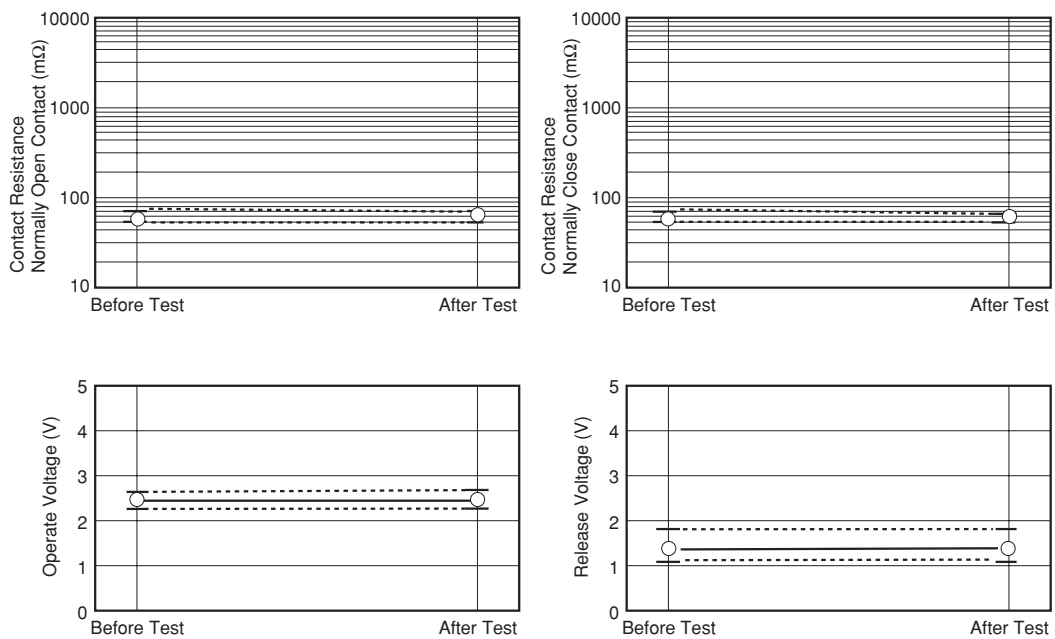

Figure 5.1 (2) High-temperature Test



- All specifications in this catalog and production status of products are subject to change without notice. Prior to the purchase, please contact NEC Tokin for updated product data.
- Please request for a specification sheet for detailed product data prior to the purchase.
- Before using the product in this catalog, please read "Precautions" and other safety precautions listed in the printed version catalog.

### 5.1.2 Low-temperature test

#### (1) Non-latching, 4.5 V Type (UC2-4.5NU, 10 Pieces)

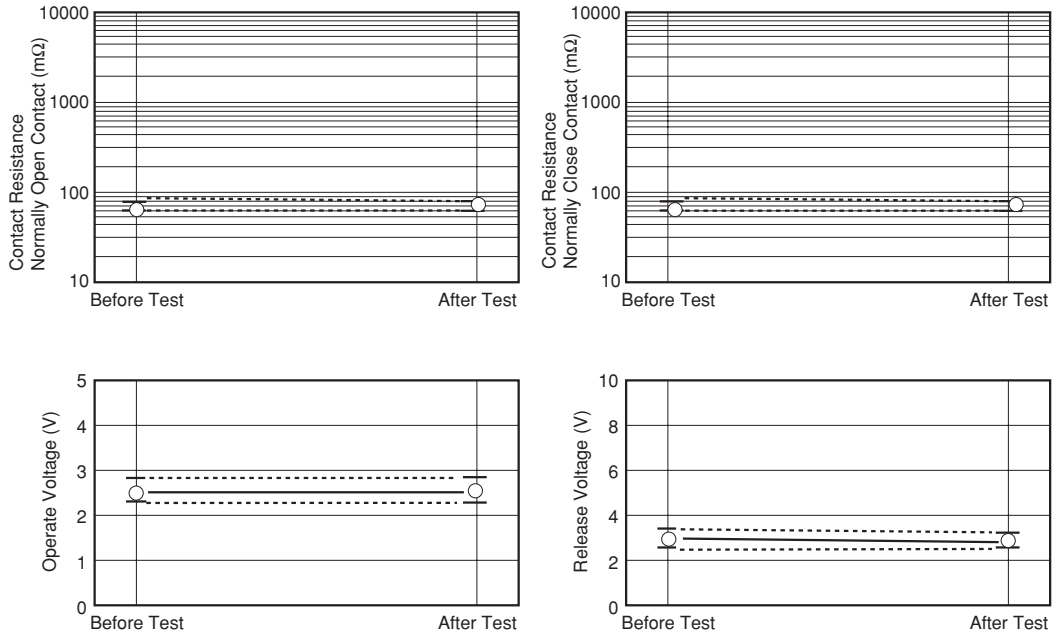

Figure 5.2 (1) Low-temperature Test

#### (2) Non-latching, 4.5 V Type (UD2-4.5NU, 10 Pieces)

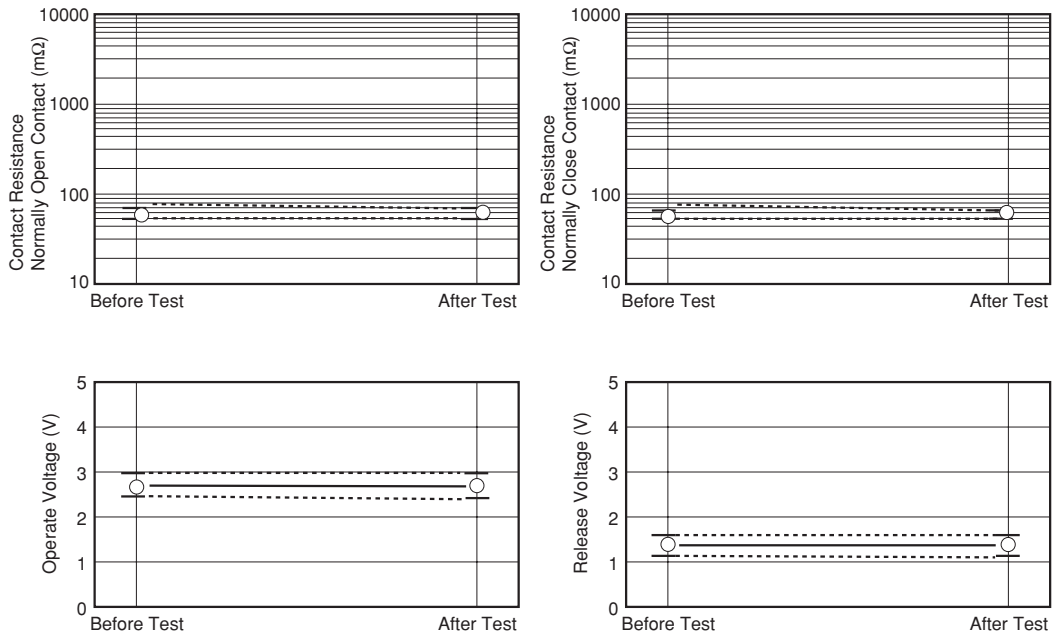

Figure 5.2 (2) Low-temperature Test



- All specifications in this catalog and production status of products are subject to change without notice. Prior to the purchase, please contact NEC Tokin for updated product data.
- Please request for a specification sheet for detailed product data prior to the purchase.
- Before using the product in this catalog, please read "Precautions" and other safety precautions listed in the printed version catalog.

### 5.1.3 Moisture resistance test

#### (1) Non-latching, 4.5 V Type (UC2-4.5NU, 10 Pieces)

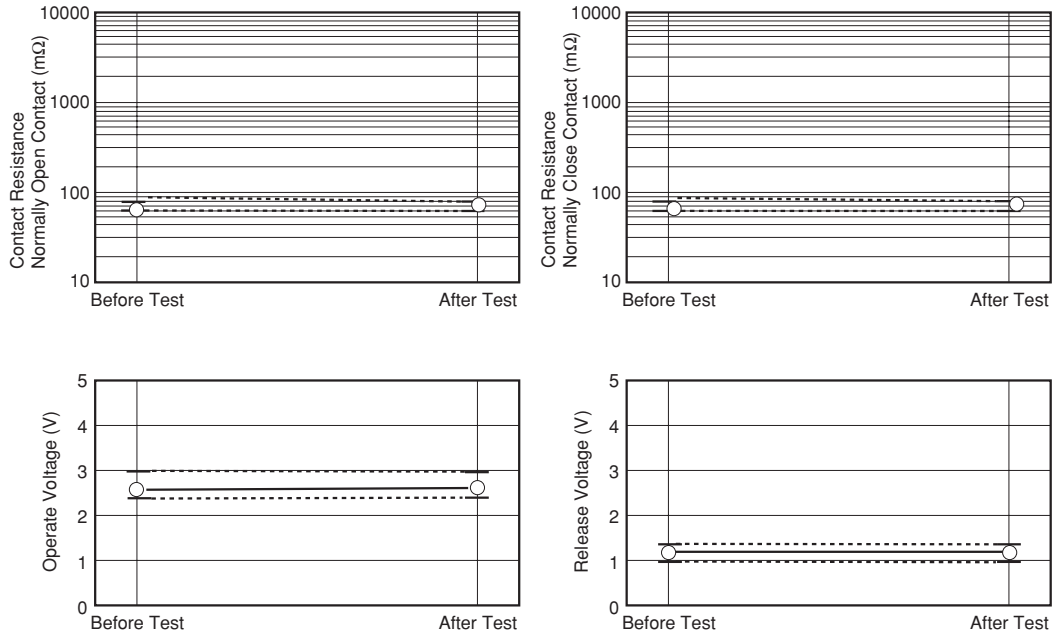

Figure 5.3 (1) Moisture Resistance Test

#### (2) Non-latching, 4.5 V Type (UD2-4.5NU, 10 Pieces)

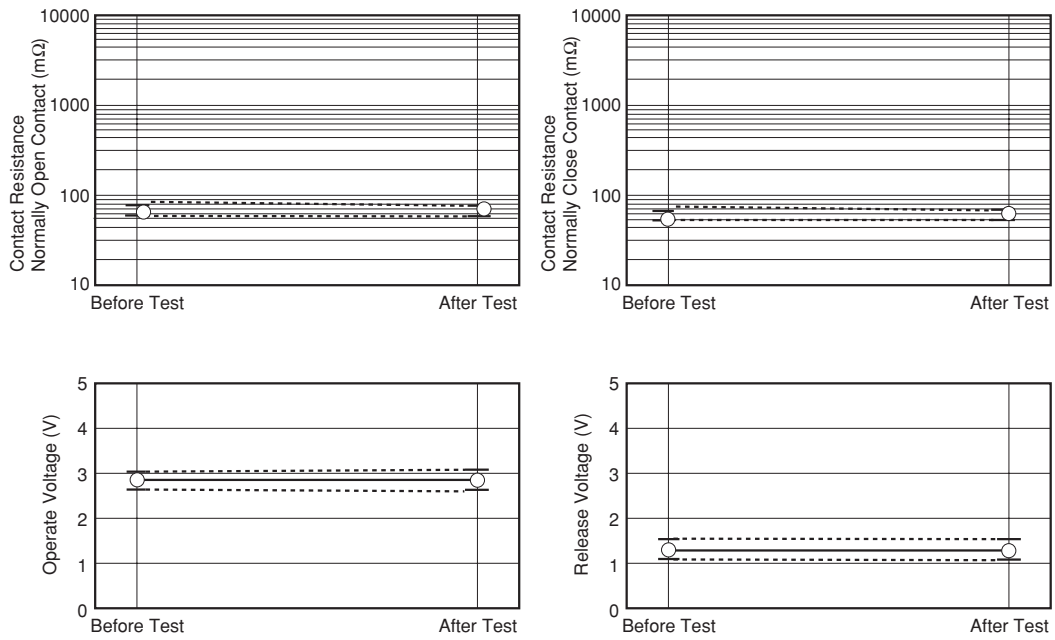

Figure 5.3 (2) Moisture Resistance Test



- All specifications in this catalog and production status of products are subject to change without notice. Prior to the purchase, please contact NEC Tokin for updated product data.
- Please request for a specification sheet for detailed product data prior to the purchase.
- Before using the product in this catalog, please read "Precautions" and other safety precautions listed in the printed version catalog.

### 5.1.4 Heat shock test

#### (1) Non-latching, 4.5 V Type (UC2-4.5NU, 10 Pieces)

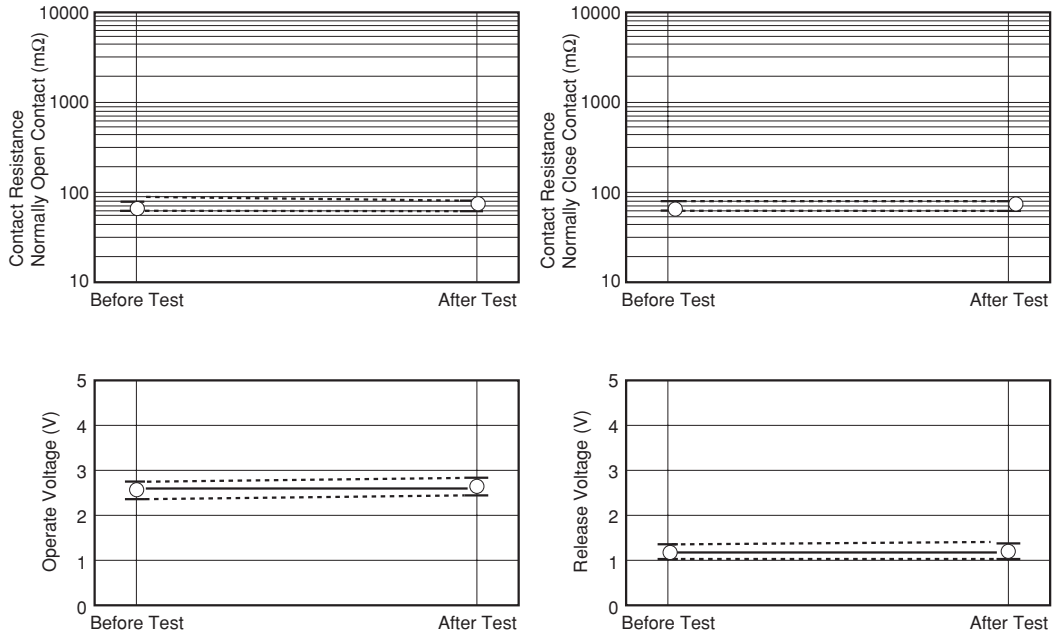

Figure 5.4 (1) Heat Shock Test

#### (2) Non-latching, 4.5 V Type (UD2-4.NU, 10 Pieces)

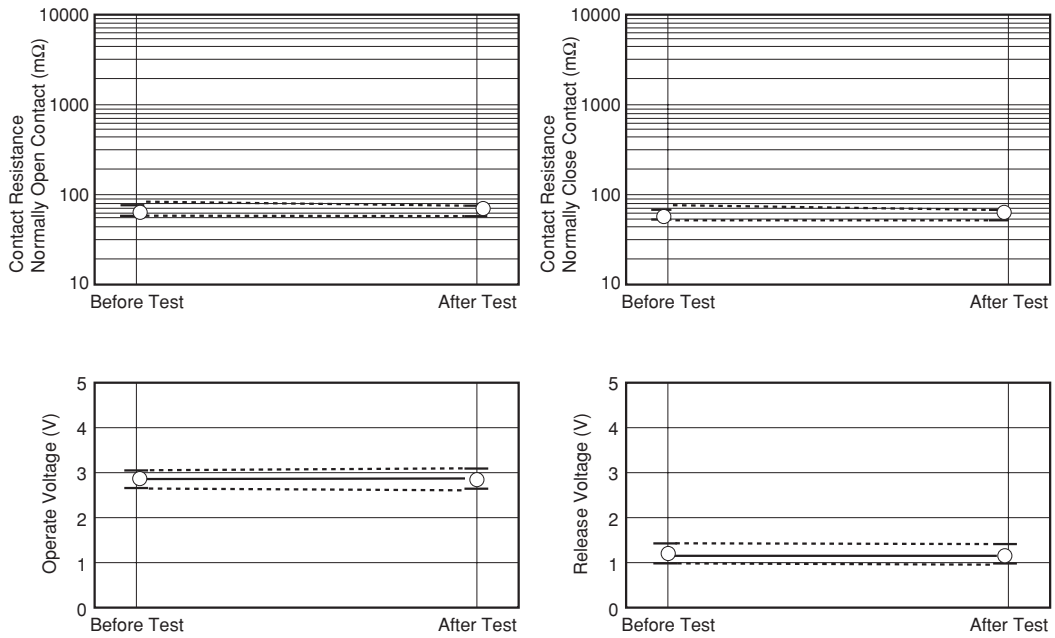

Figure 5.4 (2) Heat Shock Test



- All specifications in this catalog and production status of products are subject to change without notice. Prior to the purchase, please contact NEC Tokin for updated product data.
- Please request for a specification sheet for detailed product data prior to the purchase.
- Before using the product in this catalog, please read "Precautions" and other safety precautions listed in the printed version catalog.

### 5.1.5 Vibration test

#### (1) Non-latching, 4.5 V Type (UC2-4.5NU, 10 Pieces)

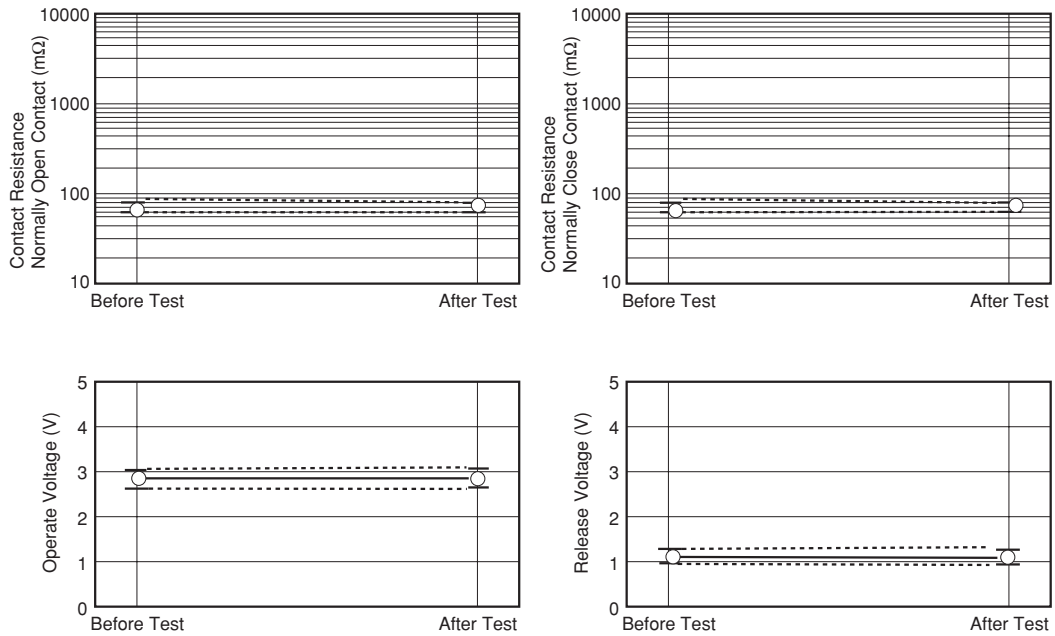

Figure 5.5 (1) Vibration Test

#### (2) Non-latching, 4.5 V Type (UD2-4.5NU, 10 Pieces)

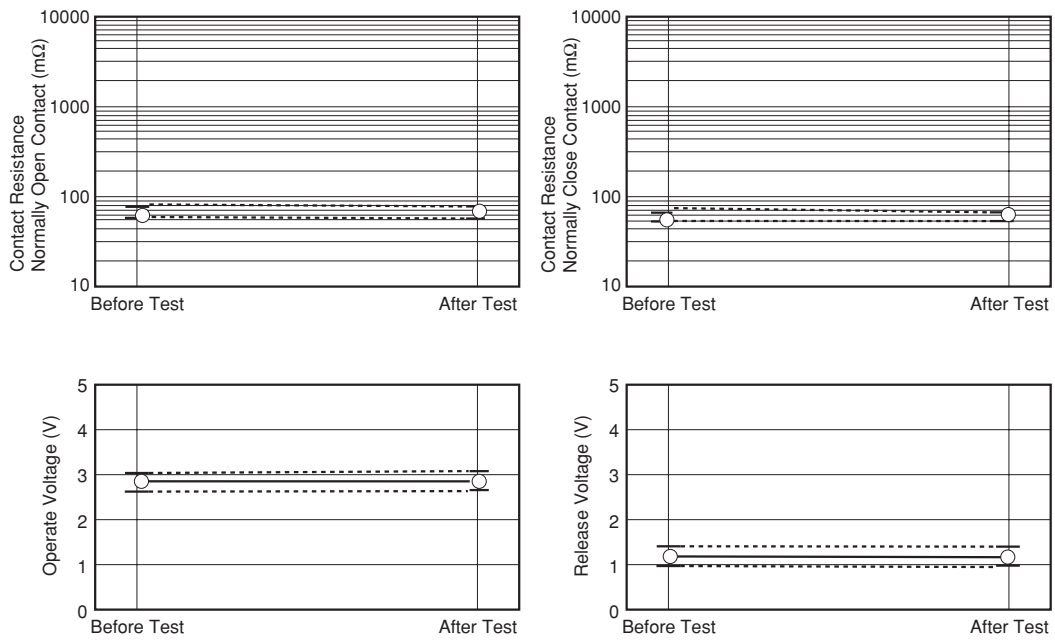

Figure 5.5 (2) Vibration Test



- All specifications in this catalog and production status of products are subject to change without notice. Prior to the purchase, please contact NEC Tokin for updated product data.
- Please request for a specification sheet for detailed product data prior to the purchase.
- Before using the product in this catalog, please read "Precautions" and other safety precautions listed in the printed version catalog.

**5.1.6 Shock test (destructive failure)**

**(1) Non-latching, 4.5 V Type (UC2-4.5NU, 10 Pieces)**

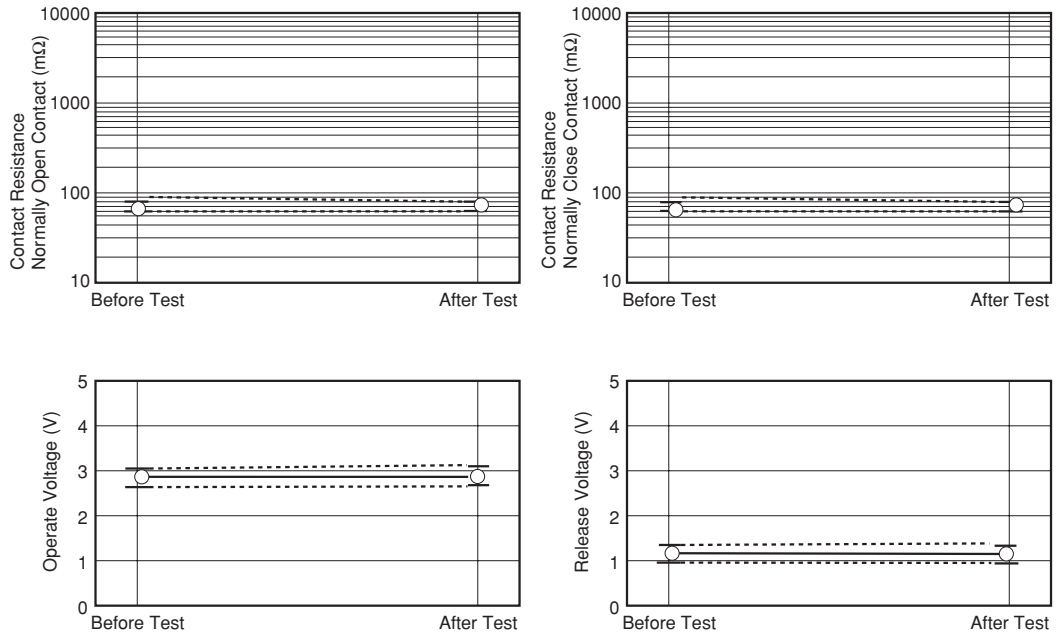

**Figure 5.6 (1) Shock Test**

**(2) Non-latching, 4.5 V Type (UD2-4.5NU, 10 Pieces)**

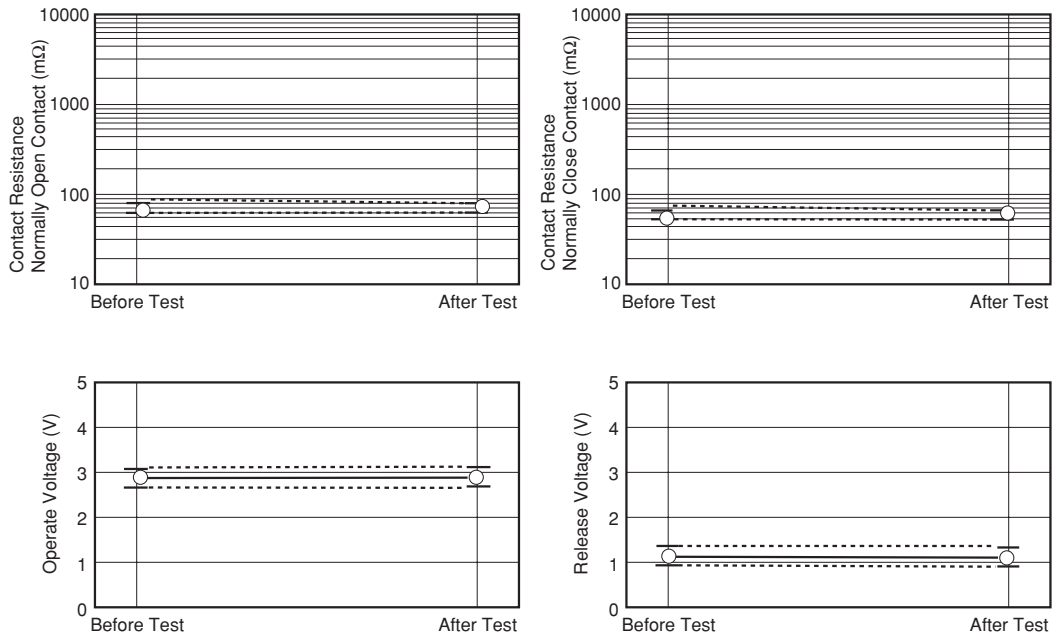

**Figure 5.6 (2) Shock Test**



- All specifications in this catalog and production status of products are subject to change without notice. Prior to the purchase, please contact NEC Tokin for updated product data.
- Please request for a specification sheet for detailed product data prior to the purchase.
- Before using the product in this catalog, please read "Precautions" and other safety precautions listed in the printed version catalog.

### 5.1.7 Shock test (misoperation)

#### (1) Testing method and samples

- Samples: UD2-5SNU 10 pieces
- Shock-applied direction: 6 directions:  $\pm X$ ,  $\pm Y$ , and  $\pm Z$  axes
- Shock pulse: Pulse time width: 0.5 ms (maximum shock 1000 G = 9800 mm/s<sup>2</sup>)
- Detection of malfunction: (1) A loose contact of 10  $\mu$ s or more is detected by a storage oscilloscope.  
 (2) The relay switch is judged to be reversed by contact continuity after the shock is applied.

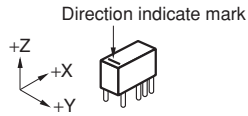

#### (2) Test results

The measured value in the below figures shows the maximum amount of shock that can be applied before malfunction occurs.

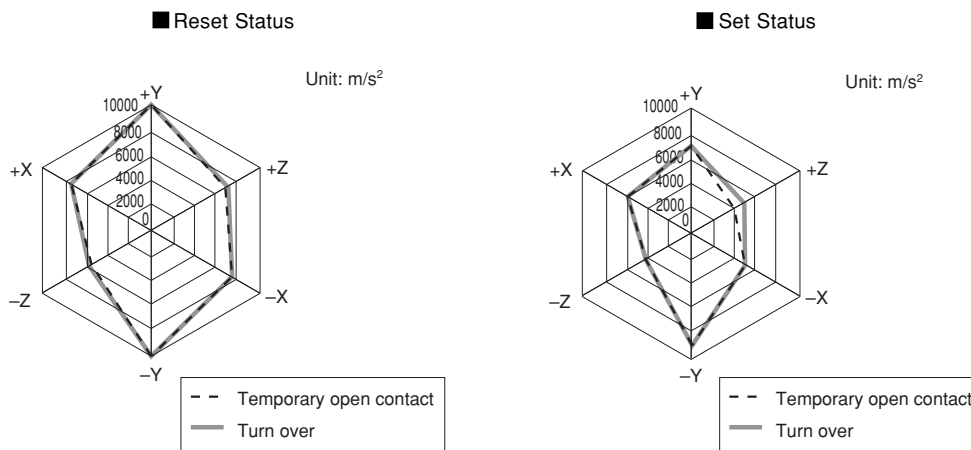

- All specifications in this catalog and production status of products are subject to change without notice. Prior to the purchase, please contact NEC Tokin for updated product data.
- Please request for a specification sheet for detailed product data prior to the purchase.
- Before using the product in this catalog, please read "Precautions" and other safety precautions listed in the printed version catalog.

### 5.1.8 Resistance to flow solder heat test

#### (1) Non-latching, 3 V Type (UC2-3NU, 10 Pieces)

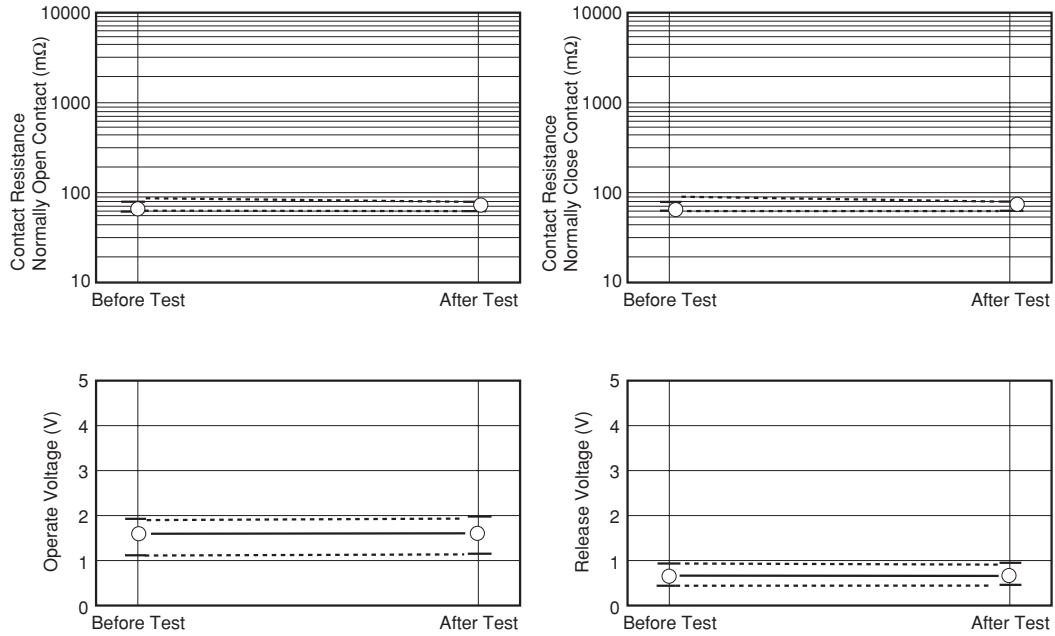

#### (2) Non-latching, 4.5 V Type (UC2-4.5NU, 10 Pieces)

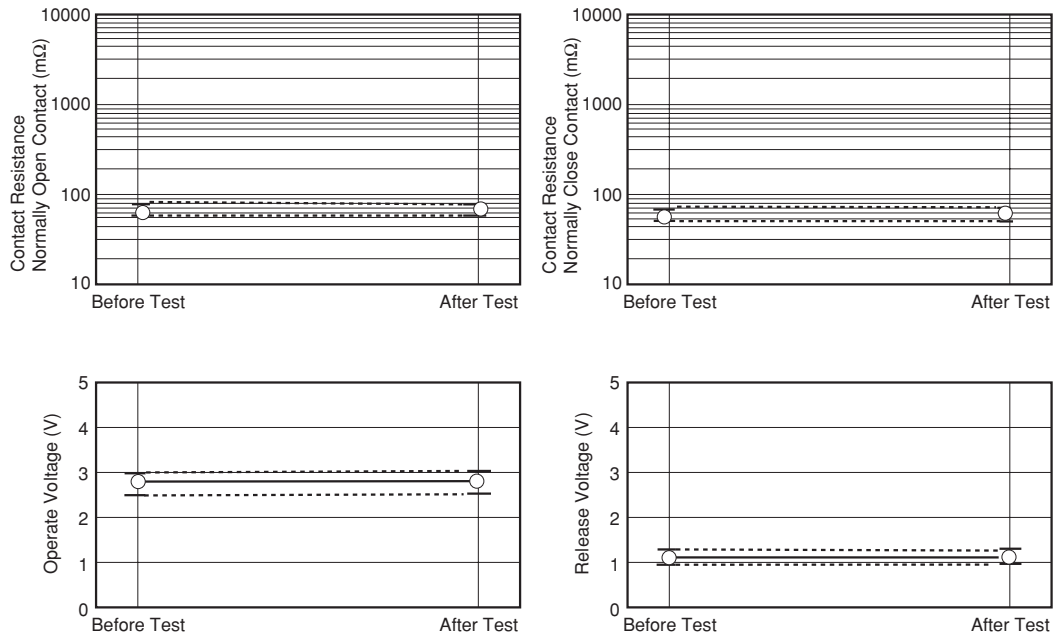

Figure 5.7 Resistance to Solder Heat Test



- All specifications in this catalog and production status of products are subject to change without notice. Prior to the purchase, please contact NEC Tokin for updated product data.
- Please request for a specification sheet for detailed product data prior to the purchase.
- Before using the product in this catalog, please read "Precautions" and other safety precautions listed in the printed version catalog.

### 5.1.9 Resistance to reflow solder heat test

This test is conducted to check whether the performance of the relay is degraded after the relay has been exposed to heat when it is soldered to a printed circuit board (PCB).

Test condition:

- <1> Soldering method: IRS (Infrared Ray Soldering)
- <2> PCB: Material epoxy-glass  
Thickness 1.6 mm  
Size 25 ×30 cm
- <3> Temperature measurement point: Printed circuit board surface near the relay terminals
- <4> Temperature profile:

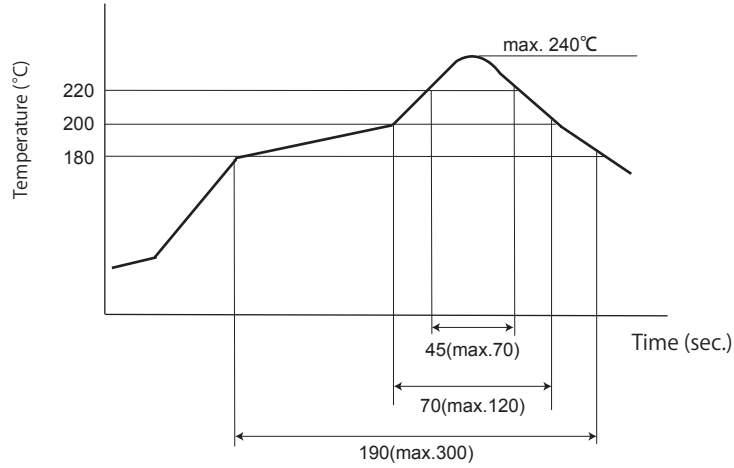

**Temperature Profiles**



- All specifications in this catalog and production status of products are subject to change without notice. Prior to the purchase, please contact NEC Tokin for updated product data.
- Please request for a specification sheet for detailed product data prior to the purchase.
- Before using the product in this catalog, please read "Precautions" and other safety precautions listed in the printed version catalog.

**(1) Non-latching, 3 V Type (UD2-3NU, 10 Pieces)**

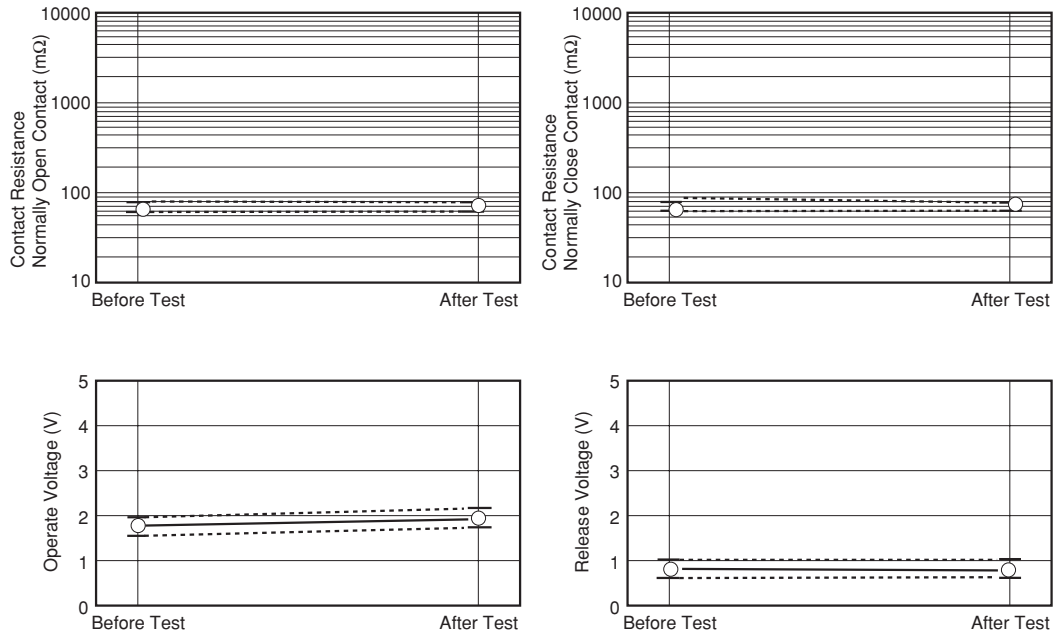

**(2) Non-latching, 4.5 V Type (UD2-4.5NU, 10 Pieces)**

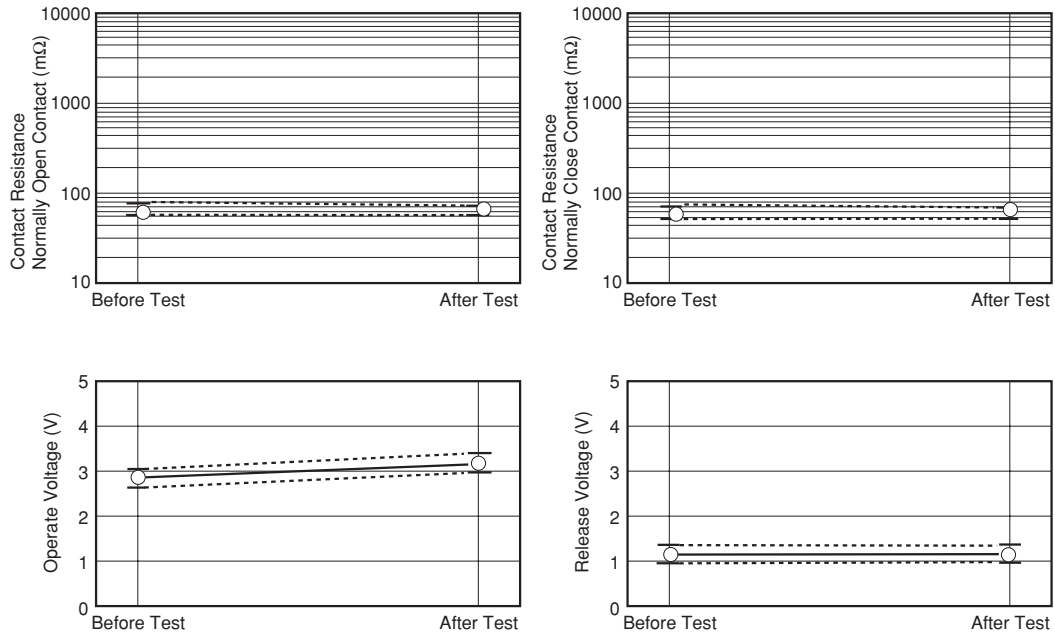

**Figure 5.8 Resistance to Reflow Solder Heat**



- All specifications in this catalog and production status of products are subject to change without notice. Prior to the purchase, please contact NEC Tokin for updated product data.
- Please request for a specification sheet for detailed product data prior to the purchase.
- Before using the product in this catalog, please read "Precautions" and other safety precautions listed in the printed version catalog.

## 5.2 Contact Life Tests

### 5.2.1 Non-load test

The cleanness of the contact surfaces influences the result of this test because no electric load is applied to the relay.

#### (1) Non-latching, 4.5 V Type (UC2-4.5NU, 10 Pieces)

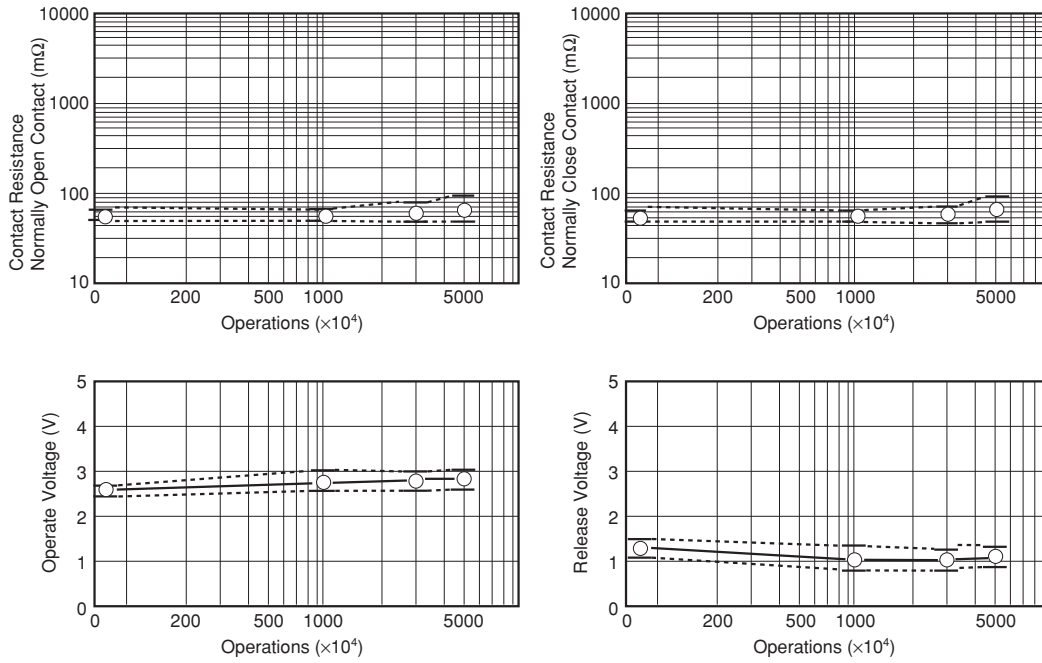

Figure 5.9 (1) Non-load Test A

#### (2) Non-latching, 4.5 V Type (UD2-4.5NU, 10 Pieces)

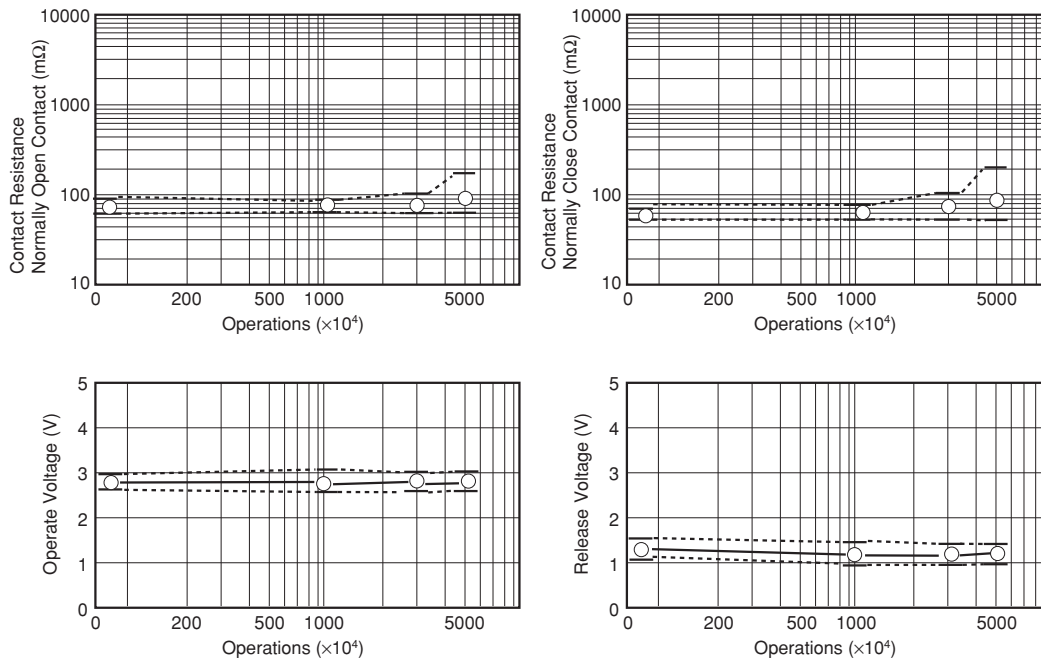

Figure 5.9 (2) Non-load Test A



- All specifications in this catalog and production status of products are subject to change without notice. Prior to the purchase, please contact NEC Tokin for updated product data.
- Please request for a specification sheet for detailed product data prior to the purchase.
- Before using the product in this catalog, please read "Precautions" and other safety precautions listed in the printed version catalog.

**5.2.2 Resistive load test A** (contact load: 50 Vdc, 0.1A, resistive, at 85°C)

**(1) Non-latching, 4.5 V Type (UC2-4.5NU, 10 Pieces)**

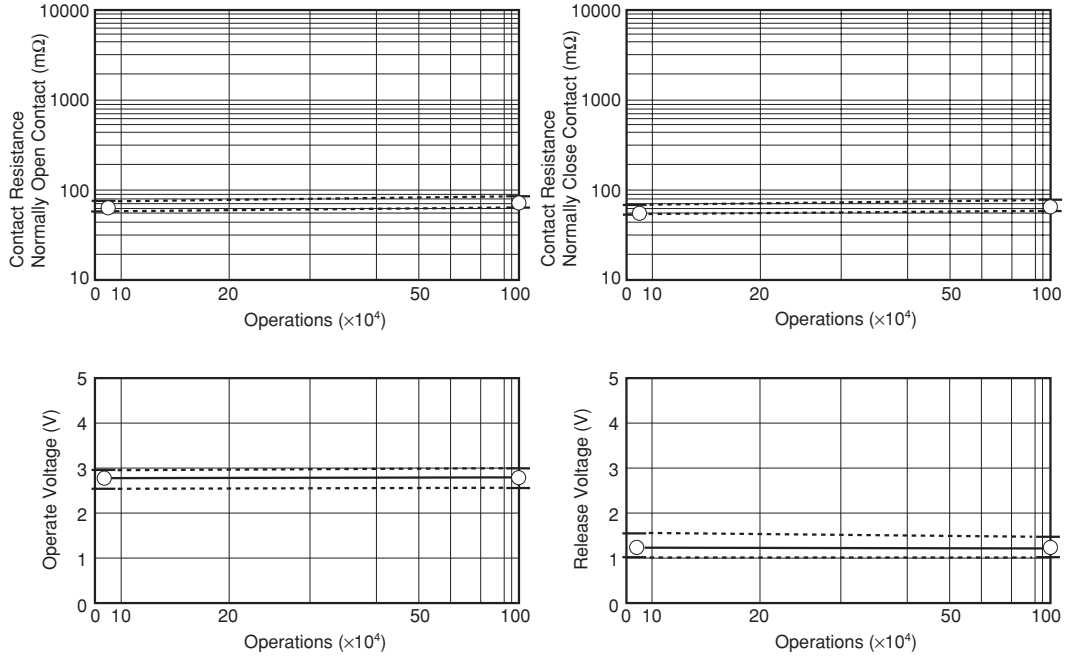

**Figure 5.10 (1) Resistive Load Test A**

**(2) Non-latching, 4.5 V Type (UD2-4.5NU, 10 Pieces)**

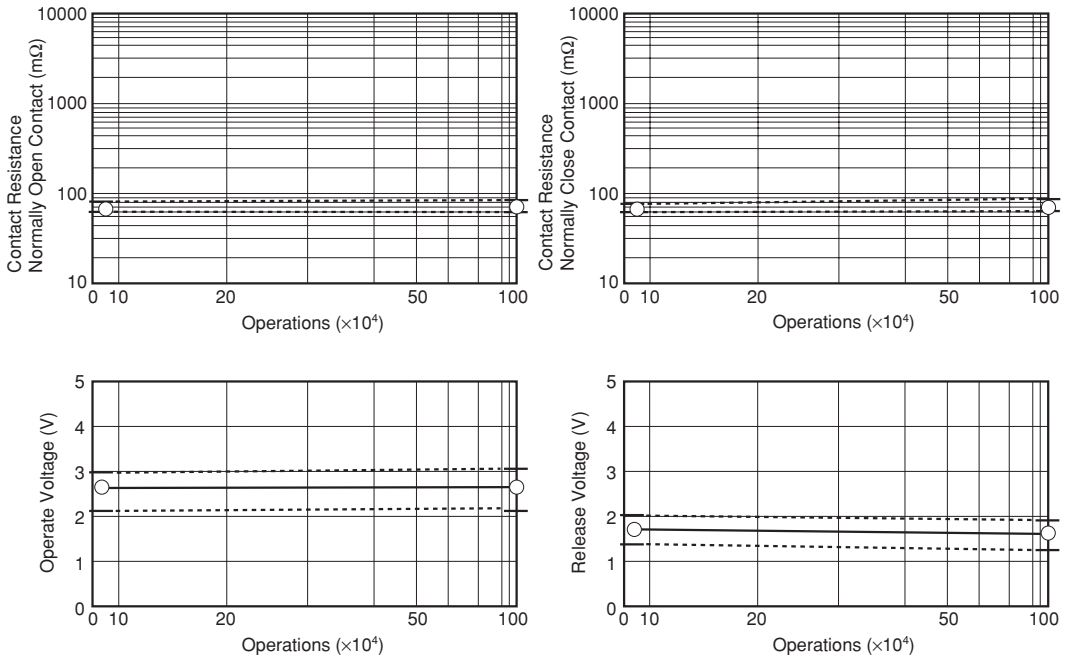

**Figure 5.10 (2) Resistive Load Test A**



- All specifications in this catalog and production status of products are subject to change without notice. Prior to the purchase, please contact NEC Tokin for updated product data.
- Please request for a specification sheet for detailed product data prior to the purchase.
- Before using the product in this catalog, please read "Precautions" and other safety precautions listed in the printed version catalog.

**5.2.3 Resistive load test B** (contact load: 30 Vdc, 1A, resistive)

**(1) Non-latching, 4.5 V Type** (UC2-4.5NU, 10 Pieces)

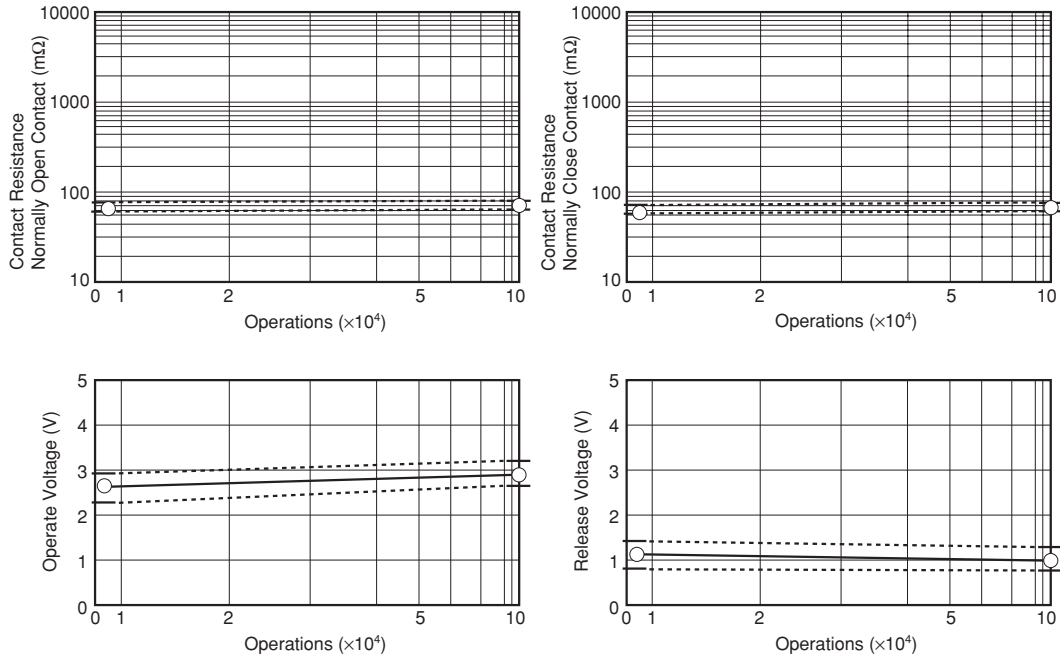

**Figure 5.11 (1) Resistive Load Test B**

**(2) Non-latching, 4.5 V Type** (UD2-4.5NU, 10 Pieces)

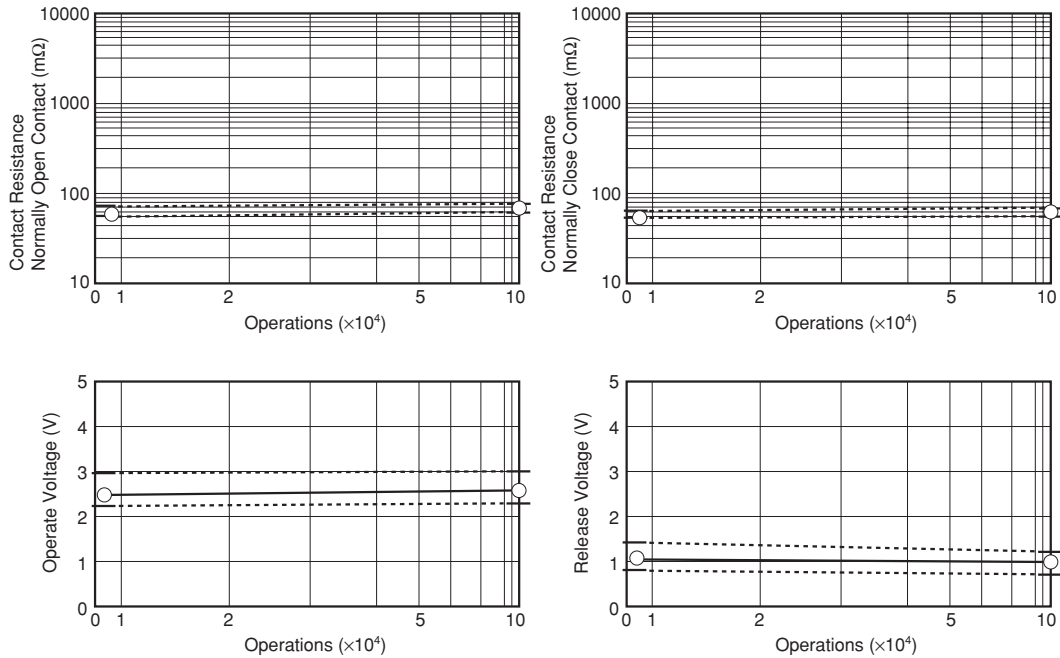

**Figure 5.11 (2) Resistive Load Test B**



- All specifications in this catalog and production status of products are subject to change without notice. Prior to the purchase, please contact NEC Tokin for updated product data.
- Please request for a specification sheet for detailed product data prior to the purchase.
- Before using the product in this catalog, please read "Precautions" and other safety precautions listed in the printed version catalog.

**5.2.4 Resistive load test C** (contact load: 125 Vac, 0.3 A, resistive)

**(1) Non-latching, 4.5 V Type (UC2-4.5NU, 10 Pieces)**

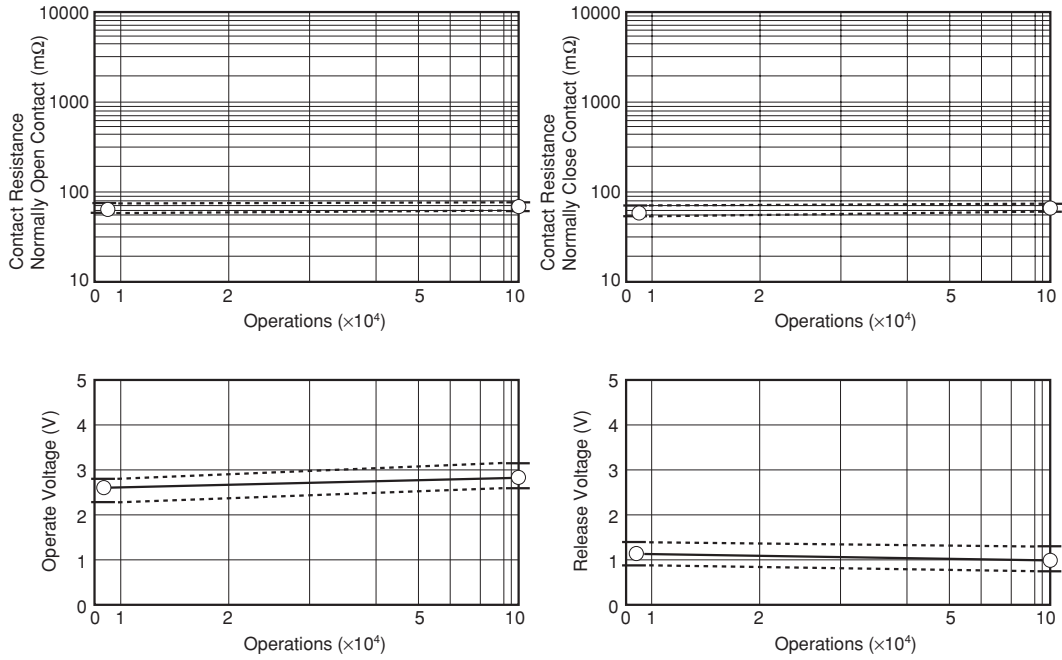

**Figure 5.12 (1) Resistive Load Test C**

**(2) Non-latching, 4.5 V Type (UD2-4.5NU, 10 Pieces)**

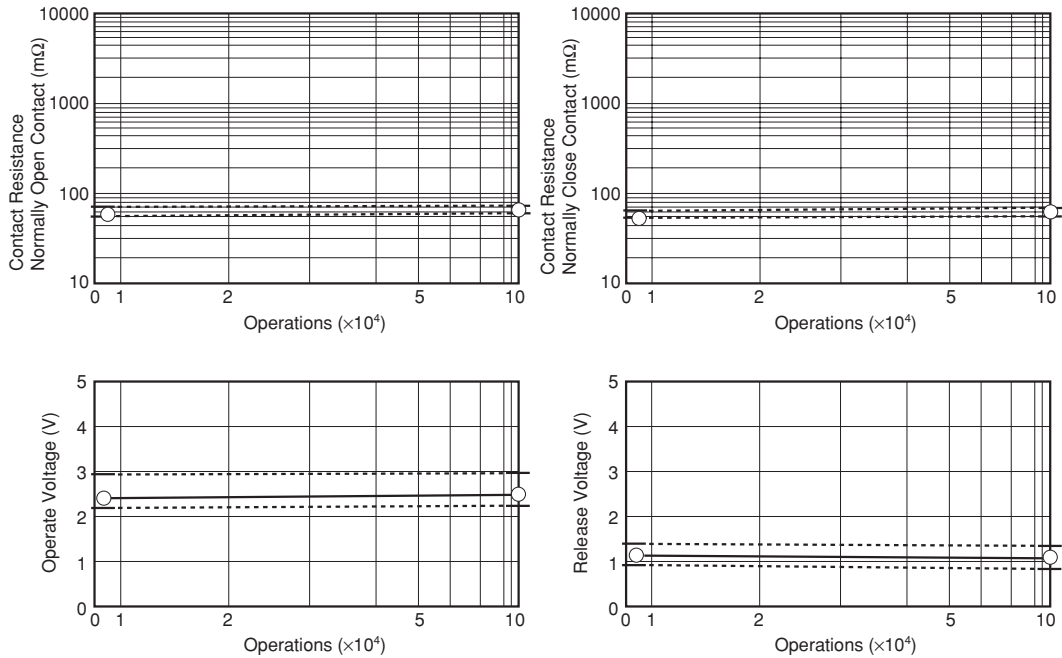

**Figure 5.12 (2) Resistive Load Test C**



- All specifications in this catalog and production status of products are subject to change without notice. Prior to the purchase, please contact NEC Tokin for updated product data.
- Please request for a specification sheet for detailed product data prior to the purchase.
- Before using the product in this catalog, please read "Precautions" and other safety precautions listed in the printed version catalog.

The information in this document is based on documents issued in March, 2006 at the latest.

The information is subject to change without notice. For actual design-in refer to the latest publications of data sheet, etc., for the most up-date specifications of the device.

No part of this document may be copied or reproduced in any form or by any means without the prior written consent of NEC/TOKIN Corporation. NEC/TOKIN Corporation assumes no responsibility for any errors which may appear in this document.

NEC/TOKIN Corporation does not assume any liability for infringement of patents, copyrights or other intellectual property rights of third parties by or arising from use of a device described herein or any other liability arising from use of such device. No license, either express, implied or otherwise, is granted under any patents, copyrights or other intellectual property rights of NEC/TOKIN Corporation or others.

While NEC/TOKIN Corporation has been making continuous effort to enhance the reliability of its electronic components, the possibility of defects cannot be eliminated entirely. To minimize risks of damage or injury to persons or property arising from a defect in an NEC/TOKIN electronic component, customers must incorporate sufficient safety measures in its design, such as redundancy, fire-containment, and anti-failure features. NEC/TOKIN devices are classified into the following three quality grades:

"Standard," "Special," and "Specific". The Specific quality grade applies only to devices developed based on a customer designated "Quality assurance program" for a specific application. The recommended applications of a device depend on its quality grade, as indicated below. Customers must check the quality grade of each device before using it in a particular application.

Standard: Computers, office equipment, communications equipment, test and measurement equipment, audio and visual equipment, home electronic appliances, machine tools, personal electronic equipment and industrial robots

Special: Transportation equipment (automobiles, trains, ships, etc.), traffic control systems, anti-disaster systems, anti-crime systems, safety equipment and medical equipment (not specifically designed for life support)

Specific: Aircrafts, aerospace equipment, submersible repeaters, nuclear reactor control systems, life support systems or medical equipment for life support, etc.

The quality grade of NEC/TOKIN devices is "Standard" unless otherwise specified in NEC/TOKIN's Data Sheets or Data Books. If customers intend to use NEC/TOKIN devices for applications other than those specified for Standard quality grade, they should contact an NEC/TOKIN sales representative in advance.

(Note)

- (1) "NEC/TOKIN" as used in this statement means NEC/TOKIN Corporation and also includes its majority-owned subsidiaries.
- (2) "NEC/TOKIN electronic component products" means any electronic component product developed or manufactured by or for NEC/TOKIN (as defined above).

DE0102



- All specifications in this catalog and production status of products are subject to change without notice. Prior to the purchase, please contact NEC Tokin for updated product data.
- Please request for a specification sheet for detailed product data prior to the purchase.
- Before using the product in this catalog, please read "Precautions" and other safety precautions listed in the printed version catalog.